



**Asia-Pacific
Economic Cooperation**

GUIDELINES FOR HOSTING APEC MEETINGS

July 2016

Note: Currently Used Hosting Guidelines doc 2015/SOM1/BMC/015 were noted by
BMC in February 2015

TABLE OF CONTENTS

	Page No.
1. Introduction	1
2. APEC Conventions	2
3. APEC Calendar and Meeting Dates	3
4. Invitations	4
5. Administrative Circulars	4
6. Host Economy Website, Registration and Accreditation	5
• Host Economy Website	
• Online Registration System	
• Identification Badges	
• Lapel Pins	
7. Accommodation	6
8. Meetings	6
• Access to Meetings	
• APEC Economic Leaders' Meeting	
• Ministerial Meetings	
• Senior Officials' Meetings and Related Meetings	
• ABAC and CEO Summit Meetings	
• Other Sub-fora, Working Group and Industry Meetings Held Outside the Margins of SOM and Ministerial Meetings	
9. Meeting Venue Facilities	11
• Host Economy Secretariat	
• Common Delegation Room	
• Member Economy Delegation Rooms	
• Registration Desk, Late Registration and Accreditation	
• Information Desk/Services	
• Meeting Room Requirements	
• Bilateral Room Requirements	
• Signage	
• Staffing – Conference Secretariat Staff	
• Improving Efficiency of APEC Meetings	
▪ Paperless Meetings	
▪ Remote Participation	
▪ Remote Listening	
10. Documentation	15
• Submission of Papers for SOM Meetings	
• Submission of Papers for Other Fora Meetings	
• Submission of Papers for Ministerial Meetings	
• Classification of Meeting Papers	
• List of Participants	
11. Delegate Services	17
• Host Liaison officers	
• Member Economy Delegation Liaison Officers	

12.	Arrival and Entry Formalities	19
	• Visas	
	• Airport Facilitation / Welcome Desk / APEC Lanes	
13.	Contact Points	18
14.	Chairs/Lead Shepherds	18
15.	APEC Secretariat	18
	• Policy and Logistical Support	
	• Communications, Public Affairs and Outreach	
16.	Security Arrangements	21
17.	Transport	21
18.	Press Accreditation, Briefings and Coverage	21
19.	Interpretation Services	21
20.	Medical Services	21
21.	Hospitality	22
22.	Sponsors	22
23.	Thematic Field Trips	23
	Annex A – APEC Secretariat Support to the Host Economy	24
	Annex B – General Logistical Requirements for the APEC Secretariat at Meetings in the APEC Host Economy	26
	Annex C – Sample Seating Layouts for APEC Meetings and Press Conferences	

GUIDELINES FOR HOSTING APEC MEETINGS

Revised Version - July 2016

1. INTRODUCTION

The purpose of the hosting guidelines is to provide guidance to APEC hosts on responsibilities, expectations, requirements, and recommendations in organizing APEC meetings. These guidelines are not meant to be overly prescriptive but rather to provide APEC meeting hosts guidance and possible suggestions on how these requirements might be met. The guidelines consist of general information applicable to all APEC fora meetings and specific notes for Ministerial and Leaders' Meetings. Where reference is made to other APEC guidelines, links to the documents on the APEC webpage is offered to provide further guidance on a particular topic. Future hosts may find it useful to consult with past hosts to gather information on best practice and norms that would contribute to a successful host year.

APEC Structure

The range of topics in which Asia-Pacific Economic Cooperation (APEC) is active reflects the complex factors and issues related to economic development, growth, and the pursuit of open trade and investment for the APEC region. APEC topics are, simply put, the areas of work covered by the APEC groups that support APEC's 'Three Pillars': Trade and Investment Liberalisation, Business Facilitation and Economic and Technical Cooperation.

APEC's working level activities and projects are guided by APEC Senior Officials from the 21 APEC Member Economies. These activities and projects are carried out by four high level committees: Committee on Trade and Investment (CTI), Senior Officials' Steering Committee on Economic and Technical Cooperation (SCE), Economic Committee (EC) and the Budget and Management Committee (BMC).

Sub-Committees, Experts' Groups, Working Groups, Task Forces and Policy Partnerships all support the activities and projects led by these four high level committees. The APEC Secretariat based in Singapore supports the work of these fora. A detailed [APEC Structure](#) diagram can be found on the APEC webpage.

Host Economy

Every year, one of the 21 APEC Member Economies plays host to APEC meetings and serves as the APEC Chair beginning 1 January and ending 31 December. The APEC host economy is responsible for chairing the APEC Economic Leaders' Meeting (AELM), selected Ministerial Meetings, Senior Officials Meetings (SOM), among others. Member economies offer to be the host economy and seek endorsement from all members well in advance.

Once agreement has been made to host a meeting, the host economy is expected to move as quickly as possible to decide on the locations and exact dates of meetings and inform all appropriate APEC contact points.

The host economy is responsible for arranging and hosting the meetings endorsed by Senior Officials during its year as Chair. It is customary for the host to include in its organizing structure two main bodies: (1) the SOM Chair's Office to handle policy issues, and (2) the APEC Organizing Committee or Task Force to provide logistical support for the meetings. The SOM Chair is nominated by the host economy to facilitate the preparations of the agenda and coordinate the work of the Senior Officials.

Arrangements to ensure a smooth transition from one host economy to the next are made following the annual AELM. It is customary for the incumbent host to continue to support the APEC process, including administrative matters requiring Senior Officials' attention, and to represent APEC until the next host officially takes over the Chair. At the same time, the new host will start collating views from all members and prepare draft policy directions, including the elaboration of a theme and a draft agenda for SOM.

Handover Formalities Between Hosts

Before handing over responsibility to the following year's host, the out-going SOM Chair prepares the annual Tasking Statement that sets out the instructions from Ministers and Leaders for the new host to undertake. Certain long-term host priorities and policy directions in a given year may require the incoming host to continue the multi-year work to meet over-arching APEC goals. Out-going hosts should provide as much information and guidance as possible after the APEC Leaders' meeting to incoming hosts on various hosting practices, documentation, policy and technical matters to ensure the new host is well informed of its responsibilities.

2. APEC CONVENTIONS

2.1 APEC as a Grouping of Economies

APEC is a grouping of economies. Therefore, other than the APEC logo, it is inappropriate to use anything, such as flags, emblems or anthems, which may imply the "political status" of any member economy. Furthermore, it is essential to use accepted APEC nomenclature (both spoken and written), during the course of the meeting and in all related documents. Members of APEC should be referred to as "member economies" or "members" or "economies". For details, please refer to the *APEC Publication Guidelines* which sets out the policy on publications and accepted nomenclature.

2.2 Language of the Meeting

English will be the medium of communication throughout the meetings.

2.3 Chairing the Meeting

The host economy may be asked to Chair or Co-chair the Meeting depending on the procedures of the particular APEC fora. For Senior Officials' and Ministerial Meetings, the host economy is almost always the Chair and, in some cases, a Co-Chair is designated. In Working Group Meetings, if the Host Economy is acting as the Chair, it would be useful to arrange for pre-meeting discussions with the Working Group Chair/Lead Shepherd and the APEC Secretariat to finalize Agenda items and scheduling of each item, to determine meeting protocols and procedures and outline expectations of the Chair and the Lead Shepherd.

2.4 Member and Non-Member Participation in APEC Activities

The current procedures for granting non-member participation in APEC activities are prescribed in the current *APEC Guidelines on Managing Cooperation with Non-Members*. The host of an APEC meeting or activity wishing to invite participants other than APEC members should consult the Guidelines which is available at the APEC Secretariat's website.

APEC has five categories of participants in all of its activities:

- Members (it is up to each member to decide whom to include in its own member delegation);
- APEC Business Advisory Council (ABAC);
- APEC Secretariat;
- Observers - currently, APEC has three observers: the Secretariat of the Association of South-East Asian Nations (ASEAN Secretariat); the Pacific Economic Cooperation Council (PECC); and the Pacific Island Forum (PIF); and
- Guests (non-members that are granted either one-off participation or three-year guest status under these Guidelines) which include all participants other than the four categories above.

ABAC has its own status as a full participant in APEC meetings, with a seat to follow after the last alphabetical economy, Viet Nam and APEC Fora Representatives (if any). The APEC Observers (ASEAN, PECC and PIF) and any official guests are then seated following ABAC.

Non-member economies (particularly those with guest status), private, regional and international organizations may be invited or are welcome to participate in APEC events and become involved in APEC Working Group activities. However, guests, unless by special invitation, are not entitled to attend the SOM, sectoral ministerial meetings and AMM, nor are they allowed to participate in policy-making sessions of Working Group meetings.

An acceptance of three-year guest status in an APEC forum (working groups, committees and task forces) application/proposed invitation will be valid for the calendar year in which the decision is made and for the following two calendar years. To renew such non-member participation, the same approval procedures as a new application/proposed invitation will apply.

The relevant forum can approve non-member participation in one-off, non-policy APEC activities, such as symposia, workshops and seminars, including joint activities with other organizations, on the delegated authority of the SOM. The acceptance will be valid only for the specific event.

2.5 Invited Guests

Invited guests can participate in APEC ministerial meetings on a consensus basis (the SOM Chair writes to all Senior Officials requesting agreement to the guest's participation). For example, in previous years the WTO Director General has participated in MRT and AMM meetings.

3. APEC CALENDAR AND MEETING DATES

APEC's year begins on 1 January and ends on 31 December. Sub-fora and Committees usually meet on the margins of and in the run-up to Senior Officials' Meetings. The calendar for the main APEC meetings in the host economy typically follows the timeline below:

Informal Senior Officials' Meeting (ISOM)	December (prior to the incoming host year)
First Senior Officials' Meeting (SOM1)	Feb/March
Second Senior Officials' Meeting (SOM2)	May/June
Ministers Responsible for Trade Meeting	Immediately following SOM2
Third Senior Officials' Meeting (SOM3)	August/September
Concluding Senior Officials Meeting (CSOM)	October/November
APEC Ministerial Meeting (AMM)	October/November
APEC Economic Leaders Meeting (AELM)	October/November

Other Sectoral Ministerial meetings, Committee, Working Group, Sub-fora and Task Force Group meetings are also held on a regular basis.

3.1 Informal / Preparatory Senior Officials Meetings (ISOM)

As noted above, there is a conventional timing for Senior Officials' Meetings. The Informal Senior Officials' Meeting in November or December preceding the incoming host year provides the opportunity for incoming hosts and economies to further brainstorm ideas and themes and to define the host's work program, preparations and meeting calendar for the following host year. A symposium is usually held on the first day with the outcomes reviewed by Senior Officials the next day at an informal meeting to elaborate on the work plan going forward.

4. INVITATIONS

Information on all APEC contact points is available on the APEC Secretariat website. The host economy is expected to issue an official invitation to all APEC members, APEC Secretariat, ABAC and APEC Observers (ASEAN Secretariat, Pacific Economic Cooperation Council (PECC) and Pacific Islands Forum (PIF)) at least eight weeks before the meeting. It should be noted that invitations to the APEC Observers are sent to the respective organisations directly. It should also be noted that hosts of APEC meetings should **not** invite any guests, other than those approved ones, to the meetings without going through appropriate approval procedures. Further guidance can be found in the *APEC Guidelines on Managing Cooperation with Non-Members*.

The responsibility for determining the location, dates and issuing formal invitations is that of the host economy's own logistics team / conference secretariat. Liaison with the APEC Secretariat and respective Missions in member economies in setting up the details of the meeting can be useful.

For Ministerial Meetings, the host economy is expected to issue an official invitation to all APEC members, APEC Secretariat, ABAC and official APEC Observers. It should be noted that the APEC Ministerial Meetings are **only** open to APEC members, ABAC, the APEC Secretariat, and APEC Observers, unless an exception is sought and agreed by consensus of member economies

through their SOM contact points. Ministerial Retreat Meetings, if held, are only open to the Ministers or their representatives, the APEC Secretariat Executive Director and registered officials of the delegation. If a Minister cannot attend, a relevant official must be appointed to represent the Minister.

For the meeting of Ministers Responsible for Trade, it has become an accepted practice that the host invites the Director General of the World Trade Organization (WTO) to attend the meeting, while the heads of International Financial Institutions are also invited to attend the APEC Finance Ministers' Meeting. However, an invitation extended to any guest should be made with the consensus of all members.

For Working Group meetings, the host economy can choose if it would prefer to inform the Chair/Lead Shepherd of the working group and ask him/her to notify all working group contact points. This can be done, if required, through the APEC Secretariat. The APEC Secretariat should be informed accordingly.

4.1 Invitation Requirements for Non-APEC Participants

Before inviting guests or non-APEC members to any APEC activities or workshops, it is advisable that the organizer of the event consult the *APEC Guidelines on Managing Cooperation with Non-Members*.

The relevant forum can approve the participation of non-members as guests in one-off, non-policy APEC activities such as symposia, workshops and seminars, including joint activities with other organizations. Non-members include non-member economies, international and regional organizations (WTO, OECD, UN, etc.), business/private sector representatives not included as members of economy delegations, academic bodies and other experts who are not included as members of economy delegations. Unless and until such consensus is obtained, invitations should not be issued.

5. ADMINISTRATIVE CIRCULARS

An Administrative Circular providing a general overview of planning and logistics considerations for each meeting is to be prepared by the host economy in coordination with the chairperson and the APEC Secretariat. This Administrative Circular is sent out to the relevant APEC contact points in advance of the meeting to enable logistical preparation by delegates. The Administrative Circular will include the following information: responsible host economy contact persons, meeting venues, liaison officers (if applicable), registration/accreditation information, arrival/entry formalities, transportation arrangements, accommodation arrangements, delegates' facilities (including common delegation room, individual delegation offices, meeting secretariat office and support, medical facilities), media arrangements (if applicable), document reproduction and distribution procedures, dress code, general local information (including information on venue city, currency, climate, electricity supply, time zones) and other information as annexes (including draft program, accommodation contact details and rates and document reproduction request forms, as applicable).

An annotated Agenda is normally prepared by the chair of the meeting to be sent out in draft to all member economies in advance of the meeting for comments. Once comments have been received, the annotated Agenda would be amended and circulated to all member delegates in good time before the meeting.

5.1 Delegate's Handbook

Past hosts have prepared a Delegate's Handbook meant to provide pertinent and updated information from the above list such as the meeting program and venues and other administrative and technical arrangements. This Delegate's Handbook, a pocket-sized "instruction manual" of sorts, is a supplementary guide provided to delegates of the participating APEC economies just prior to the meeting or on arrival and serves as a useful reference if it is able to capture the very latest scheduling updates and information on meeting venues. Alternatively, scheduling updates can be provided in circulars or notices as information becomes available. To facilitate economies' understanding of material in circulars, consistency

of presentation across all circulars is important. This need for consistency also applies to delegate handbooks.

5.2 Distribution and Timing

The most effective means of distributing Administrative Circulars at present time is through email channels or by posting it on the host economy' website. Administrative Circulars are generally distributed 6-8 weeks prior to the meeting.

6. HOST ECONOMY WEBSITE, REGISTRATION AND ACCREDITATION

6.1 Host Economy Website

The incoming host is encouraged to develop a host website in advance of its host year with the aim of publicising key information such as the meeting schedule for the year, information on major meetings and venues, speeches, news, announcements and accreditation facilities for both delegates and media, among other items. The Host Economy website should have an English version. The host economy may localize the website and develop other versions for the local language. The APEC Secretariat is able to provide guidance on developing the host economy website. More details can also be found in *the APEC Websites Guidelines*.

6.2 Online Registration System

Host economies for SOM and related meetings over recent years strongly encourage delegates to register for their attendance at meetings on-line through a secure internet connection. The designated Delegation Liaison Officer (DLO) should register the economy's delegates in advance through the host economy's Accreditation website by the stipulated deadline as set out in the Administrative Circular. User names and passwords are generally provided to all APEC economies, APEC Secretariat, ABAC and APEC Official Observers. The username and password is needed to access the accreditation site.

When selecting and implementing an online registration system, hosts should ensure that the system possesses some basic requirements, e.g. ease of use, ability for the registrant to select specific meetings for attendance, the ability to generate a confirmation notice to the registrant, and the ability to capture all relevant information pertaining to each registrant.

The system needs to be reliable, secure, and able to guarantee the integrity and recoverability of any information held in it.

The registration document needs to capture full details of the delegate including passport details, intended travel dates, and a colour photograph. When the registration is complete, the confirmation report should be printed at the source and held by the delegate.

On the registration for the 'Invited Guests' category, APEC Secretariat will, on their behalf, facilitate their accreditation with the host as these Guests may not fall under an economy's registration/ accreditation channel for SOM and related meetings or may hail from a non-member economy.

6.3 Identification (ID) Badges

Upon arrival at the meeting venue, delegates pick up their ID badges at the Accreditation Desk and may be requested to provide identification in order to do so. ID badges should be worn at all times and are required for entry to all official venues and meeting areas.

6.4 Lapel Pins

Lapel pins are issued to Ministers and their spouses; the SOM Chair, Senior Officials, Chairs of the Committee on Trade and Investment; Economic Committee, Budget Management Committee, and Steering Committee on ECOTECH; and APEC Business Advisory Council (ABAC); the APEC Secretariat Executive Director; and heads of official Observer delegations (ASEAN, PECC and PIF). In instances where a person holds a dual role as both Committee Chair and Senior Official, only one lapel pin should be provided to that person

Lapel pins should be worn at all times and are similarly required for entry to all venues and meeting areas.

7. ACCOMMODATION

The host economy is expected to arrange block bookings with a range of room rates to offer participants a choice at appropriate hotel(s) within or close to the meeting location. Normally, these preferential rates should be applicable from a few days before the meeting until a few days after the meeting. Information concerning the hotel(s), rates, other pertinent information, and hotel reservation forms should be forwarded to the APEC contact points and the APEC Secretariat at least eight weeks before the meeting (at the same time the invitations are issued to all member economies). It is normal practice that the host economy books directly with the hotels concerned or channels bookings through a host organization depending on local preferences. It is also acceptable for the host economy to request participants to make bookings directly with the designated hotels. Giving a deadline to take advantage of negotiated hotel rates is helpful to participants and the host and should reduce inconvenience. Ideally, hotel room rates are inclusive of internet charges.

The host economy is responsible for preparing a list showing the hotel accommodation for the different delegations of the economies. This is particularly necessary if delegations are staying in more than one hotel. Delegations wanting to arrange for suites or reserve meeting or function space at any hotel should contact the hotel directly.

The host economy may wish to make special arrangements to facilitate the check-in of the participants to the hotel. The host economy may also wish to arrange for meeting notices and local tourism material to be provided at the reception or in the participants' hotel rooms on arrival. It is quite acceptable for the host economy to publicise local tourist attractions and other pertinent local information to participants in such a way as to encourage them to stay on at their own expense or return at some future time.

For Ministerial meetings the host economy generally provides hotel accommodation and local transportation for the Ministers and spouses, the APEC Secretariat Executive Director, the ABAC Chair and the heads of the Observer delegations (ASEAN Secretariat, PECC and PIF), which should all be, in principle, to the same standard.

8. MEETINGS

To facilitate the smooth operation and minimise disruptions to the meeting, it is customary to limit the number of delegates entering the Senior Officials' or Ministerial meeting room by issuing a limited number of overpasses per economy. The exception is for the SOM Chair's Office and the APEC Secretariat which need sufficient overpasses to allow their officials to support the meetings as necessary. Ministers, Senior Officials, and Committee Chairs are generally assigned lapel pins which allow them free access to the meeting rooms. It is understood that each economy will coordinate internally to determine who shall have the access pass to participate or assist their Senior Official as required. For other Task Force Chairs, Lead Shepherds, and invited guests, it is customary for the SOM Chair's Office, which controls the meeting agenda to consider issuing passes and facilitate their attendance whenever they are required to report to the meeting. Often, this can be coordinated and assisted by the APEC Secretariat.

It is customary for the host economy to provide drinking water at the table during the meeting, and morning and afternoon refreshments for the participants.

8.1 Access to Meetings

Meeting overpasses are generally required to enter SOM and Ministerial meetings, with the exception of lapel pin wearers who will not be required to possess a meeting overpass. For SOM meetings, each economy delegation is normally provided with six (6) meeting overpasses with the ABAC Secretariat, the three Observer Organizations, and approved guests provided with an appropriate number of overpasses. The APEC Secretariat (including the Policy Support Unit) is generally provided ten (10) meeting overpasses. For ministerial meetings, six (6) to eight (8) meeting overpasses are provided for economy delegations and APEC Secretariat and an appropriate number for ABAC Secretariat, the three Observer Organizations, and approved guests. These procedures are intended to expedite access for authorized delegates to the restricted

plenary meetings with minimal inconvenience and to ensure adequate and comfortable seating for all participants.

8.2 APEC Economic Leaders' Meeting

The APEC Economic Leaders Meeting (AELM) is held once a year in the APEC host economy. Declarations from these meetings set the policy agenda for APEC.

The following provides additional information on administrative arrangements for the AELM. It is intended to provide practical advice for consideration by host economies based on past practices and experiences. Host economies should consider their own circumstances and consult with members prior to making arrangements for this meeting. As the arrangements by hosts have varied from year to year, it is useful that a host economy gathers the information regarding the practices by previous hosts to guide their own planning.

The AELM is considered the highlight of the APEC year. The host economy will usually work out an agreed date with members for the AELM, consulting up to two years ahead in terms of planned economy key dates (e.g. elections, key national holidays, etc.). The meeting is normally held in the last quarter of the year.

APEC Leaders implicitly understand that they are invited to attend this meeting; the letter of invitation from the host economy's leader is simply a formality. In the past, an invitation letter was sent out around May by the head of the host government to APEC counterparts. This is to extend an official invitation to all APEC Leaders and spouses with the details of the theme and expected outcomes of the Leaders' meeting at the end of the year, the venue of the meeting and other administrative arrangements. Then, about one month before the Leaders' meeting takes place, another letter from the head of the host government would be sent out elaborating on the details of the program, agenda and the arrangements for the meeting. In some instances, this may also include an arrangement for bilateral visits or meetings that will take place in the margins of the AELM.

As the AELM is considered to be an informal meeting, the protocol accorded should also be kept simple and less formal. Generally, the host economy provides basic hospitality to the attending Leaders and spouses as prescribed in these Guidelines. These include accommodation during their stay, security, domestic transportation and necessary protocol. The host may also organize a separate program for spouses for charitable activities or sightseeing.

There is no formality for the arrival and departure of foreign leaders. However, it is expected that the protocol accorded to Leaders' would be similar to a working visit, with an appropriate representative of the host government present at the arrival and departure of all Leaders. The official welcoming is usually conducted on the first day of the Leaders' retreat.

In the past, the hospitality arrangements have varied, as economies' protocols in receiving foreign guests are different. Some APEC Leaders have combined attendance of the AELM with bilateral state/official visits, which made it more difficult to determine the appropriate protocol. In certain economies where the head of the government is not the head of state, an arrangement may be made for APEC Leaders and spouses to pay a courtesy call on the head of state. This arrangement however is not part of the APEC protocol but is part of the host economy's hospitality accorded to foreign Leaders.

The arrangements for the AELM are decided by the host economy. Past practices have seen an official program over two days. The first day usually starts in the afternoon with the official welcome and the first retreat session of the 21 Leaders. This is followed by a dialogue session with all members of the APEC Business Advisory Council (ABAC). The evening dinner program is for socializing among Leaders and an opportunity for the host economy to showcase its cultural heritage. The second day usually starts with the second retreat session of 21 Leaders in the morning. As has been practiced in recent years, the retreat session is followed by a working lunch when Leaders devote the time for discussion of specific topics of high importance to the region. At the end of the working lunch, it is customary that all Leaders assemble behind the chairman of the year to read out the main points of their discussions as well as the Leaders' Declaration. This will be the highlight of the day when the presence of the 21 Leaders are

watched the world over. The reading of the Leaders' Declaration marks the end of the official program for the AELM.

As this meeting is considered to be informal, the host economy will usually prepare the program with less protocol and agenda. Also, it has been the custom since the first AELM (with the exception in recent years) that the host economy will provide the Leaders with an outfit that reflects the host economy's national or traditional attire. The wearing of the attire, seen most strikingly when Leaders line up together for the reading of the Declaration and the official photograph, has become the most important media opportunity of the Leaders' meeting.

The venues for both sessions of Leaders' retreat, dialogue with ABAC and the evening dinner are determined by the host economy. A number of factors such as security, convenience, cultural significance are often taken into account.

Although the host economy is not required to provide bullet-proof or armoured limousines for visiting Leaders, in light of increases in terrorism, hosts often ensure maximum protection for all Leaders and ministers. In certain cases, sponsorship can be arranged to alleviate the substantial budgetary burden to the organizing government.

8.2.1 Seating Arrangements

For the Leaders' retreats, the seating plan will be arranged to allow maximum comfort and intimacy. Also, there is no protocol that requires Leaders to be seated by alphabetical order as prescribed in the arrangement for Ministers and SOM. The seating arrangement will be determined by the host economy, but it is usually made in consultation with Senior Officials.

During the retreat sessions, only 21 seats are arranged for Leaders, with an exception for the SOM Chair to sit behind the host to provide support and advice to the Chair. Other Senior Officials, security personnel, entourage and interpreters will be seated in an adjacent room with audio and visual feeds. Prior to 2003, sit-down meetings were arranged for the ABAC's dialogue with Leaders can take the form of sit-down meetings with a presentation to Leaders, followed by a questions-and-answers session, small group breakouts with individual Leaders or in a cocktail format where all Leaders and ABAC members can mingle and discuss issues in an informal manner.

8.2.2 Press Conference

The reading out of the Leaders' Declaration is considered the highlight of the AELM. The host economy may consider another press conference by the Chair of the year to elaborate and give more detailed outcomes, including comments on the meeting. This does not require the presence of other Leaders. In some cases, depending on the arrangement between the present and the next host Leaders, a press conference may be held to outline the theme for the next APEC year.

8.2.3 Documentation Process

As the aim is to provide an atmosphere where Leaders can exchange their views freely in an informal manner, there is no procedure for the preparation of meeting documents. The host economy will be responsible for preparing the agenda and providing any relevant information. However, this should be kept to a minimum and will not be circulated or referred to. The only official record of the meeting is the Leaders' Declaration.

8.2.4 Preparations for Advance Visits (For Leaders' Meeting)

Advance Visits provide economies with a first-hand understanding of the arrangements for the Leaders' Meeting. Early decisions should be made on the number of Advance Visits and their timing. Conveying these details to economies early in the APEC year greatly facilitates the involvement of key decision makers and personnel from economies in the Advance Visits.

During Advance Visits, economy delegates are able to observe the logistical preparations and to hold bilateral consultations on the upcoming visit by their respective Leaders. A two-day briefing often takes place sometime between the middle of the year and August to update participants on the preparations leading up to the AELM. This is combined with visits to the sites planned for the Leaders' meeting and other functions and is usually attended by representatives

of the diplomatic missions located in the capital of the host economy. Information will be conveyed to their respective Senior Officials and relevant government agencies responsible for planning the foreign visits of Leaders.

A second visit may take place around six weeks before the actual APEC Economic Leaders' Meeting (AELM). This visit is often arranged for three days and is attended by senior delegates from the Office of the President or Prime Minister who will look into details of the final arrangements. A final inspection of the sites that will be visited by Leaders and a briefing on every detail of each program are also arranged. Bilateral consultations are common for members to discuss specific needs by their Leaders. These needs often relate to security protection, medical, protocol, transportation, and the personal program of the Leader and spouse.

8.3 Ministerial Meetings

Annual APEC Ministerial Meetings of foreign and economic/trade ministers are held immediately prior to APEC Economic Leaders' Meetings. Ministers take stock of the year's activities and provide recommendations for Economic Leaders' consideration.

Sectoral Ministerial Meetings are held regularly covering areas such as education, energy, environment and sustainable development, finance, human resource development, regional science and technology cooperation, small and medium enterprises, telecommunications and information industry, tourism, trade, transportation and women's affairs. Recommendations from these meetings are also provided to APEC Economic Leaders for their consideration.

The APEC Ministerial Meetings are only open to APEC members, the APEC Secretariat and APEC Observers, unless an exception is sought and agreed by consensus of member economies through their SOM contact points. The Ministerial Retreat Meetings (if a retreat format is organized) are only open to the Ministers or their representatives, the APEC Secretariat Executive Director and key Secretariat staff. If a Minister cannot attend, a relevant official must be appointed to represent the Minister.

For the meeting of Ministers Responsible for Trade, it has become an accepted practice that the host invites the Director General of the World Trade Organization (WTO) to attend the meeting, while the heads of International Financial Institutions are also invited to attend the APEC Finance Ministers' Meeting. However, an invitation extended to any guest should be made with the consensus of all members.

Similarly, the APEC Finance Ministers Meeting (FMM) is only open to APEC members, Deputy Finance Ministers, Senior Finance Officials (SFOM), the APEC Secretariat and APEC Observers, unless an exception is sought and agreed by consensus of member economies through their SFOM contact points. If a Minister cannot attend, a relevant official must be appointed to represent the Minister.

It is customary for the Executive Director (ED) and the Director (Program) responsible for the Ministerial Meeting to participate in Ministerial Meetings. The ED should be accorded treatment and courtesies equivalent to Ministers, including the opportunity to give a short presentation on APEC developments affecting the issues under discussion.

The host economy usually meets the cost of Ministers', the Executive Director and official Observers' suites on the eve of and during the official days of the meeting. Ministers (or their designates), the ABAC Chair, the ED and Heads of official Observer delegations are usually provided with a car and driver.

Access to the plenary sessions at Sectoral Meetings is usually limited to 8 (eight) seats per economy. Additional delegates will be able to observe the meeting from the Viewing Room where this is provided. The APEC Secretariat sits along with the 21 members in all its retreats. A seat should also be available, next to the Minister, for the respective Lead Shepherds in both forum and plenary sessions.

8.4 Senior Officials' Meetings and Related Meetings

Working under direction from APEC Ministers, Senior Officials guide the activities of the Committees, Working Groups and Task Forces. Senior Officials develop recommendations for APEC Ministers and APEC Economic Leaders. Senior Officials' Meetings are held three to four times a year and is chaired by the host economy.

The host economy is expected to issue an official invitation to all the APEC members, the APEC Secretariat, ABAC and APEC Observers (ASEAN, PECC and PIF Secretariats) at least eight weeks before the meeting.

8.5 ABAC and CEO Summit Meetings

ABAC provides APEC Economic Leaders with a business perspective on APEC issues through an annual meeting and a formal report. The annual report contains recommendations to improve the business and investment environment in the APEC region. ABAC also meets four times per year and is invited to all APEC Meetings (except Ministerial and Leader retreats).

Every year since 1996, the host economy has held an APEC CEO Summit during AELW as an element of its overall hosting of APEC. Occasionally the format has differed, but generally this has been a major conference organized and funded by a private sector-led body chosen by the host economy. Prior to the beginning of its host year the host economy will formally decide who the organising body will be and how the event will be funded. Usually the organiser is the host ABAC team, who in turn often designates one member to be responsible for the event. Usually, that member leads a planning committee which oversees all elements of the event, in collaboration and consultation with the host economy government. The planning committee contracts with various service providers in the execution of the event, including hotels, caterers, program consultants, security companies, transport companies, sponsor recruitment and support companies and event production companies among others. Other economies' ABAC members usually work with the committee to invite participants to the event. The organizer and the entities it has contracted with will follow the guidelines for the APEC CEO Summit laid down in the ABAC Handbook for Members.

The host economy should work with APEC CEO Summit organizers and the APEC Secretariat to ensure that APEC CEO Summit arrangements follow relevant APEC nomenclature, conventions, arrangements for Leaders, and protocols and guidelines with respect to appropriate use of the APEC brand and copyright considerations contained in the [APEC Logo Guidelines](#) and the [Intellectual Property Policy](#), and also relevant parts of the [APEC Hosting Guidelines](#).

As a key element of its APEC hosting, the current host economy should work with the APEC CEO Summit organizers to ensure good governance and to, in general, align the Summit's themes with the current APEC host's agenda. To enhance communication and transparency, the current host economy should work with APEC CEO Summit organizers to brief SOMs on meeting arrangements and themes at ABAC1 and SOM1, and throughout the year. In particular, ABAC should ensure economies have all the relevant information, including logistics, topics and format in advance of CSOM in order to facilitate the participation of economic leaders, which is an annual event during AELM.

If other similar business events, such as the APEC SME Summit, are also being organized, they should follow the applicable APEC procedures and guidelines. In addition, SOMs may request further information on the APEC CEO Summit from the host economy. Further guidance can be sought from the APEC Secretariat at info@apec.org or the ABAC Secretariat at abacsec@pfgc.ph.

8.6 Other Sub-Fora, Working Group and Industry Meetings Held Outside the Margins of SOM and Ministerial Meetings

The arrangements for Working Group and Sub-foa meetings are quite similar to that for SOM meetings but with less protocol and formality. While it is important for the host to provide efficient support for a fruitful meeting, there are fewer requirements on hospitality from the host and organizer of the meeting.

Normally, the responsibility to organize the meeting rests with the Lead Shepherd or Chair of the fora. However, as it has been customary for member economies to take turns in providing venues for the meeting, it is important that the host also assists the Lead Shepherd or Chair arrange the logistics of the meeting to allow the latter to concentrate on substance and policy.

The host economy is expected to issue an official invitation at least eight weeks before the meeting to relevant APEC members, APEC Secretariat, APEC Observers and guests (each working group and/or Sub-fora may have its own list of official guests). The host economy can choose if it would prefer to ask the Chair/Lead Shepherd of the working group to notify all working group contact points. This can be done, if required, through the APEC Secretariat, and it should be duly informed. Hosts of APEC meetings can only invite guests approved through the appropriate procedures. Please refer to the current *APEC Guidelines on Managing Cooperation with Non-Members*.

Depending on the shape of the meeting room and the number of participants, seating arrangements for Working Group and Sub-fora meetings usually use a “hollow circular, oval, rectangle or square” setting. Additional seating is usually required around the room behind the delegation table to allow additional members to be seated close to their respective delegates at the table.

It is not necessary to provide meals to participants. Nonetheless, host economies may choose to provide working lunches during the meeting and host a dinner and/or reception for participants (sometimes in conjunction with local business sector representatives). It is entirely up to host economies to decide how to show their hospitality. Photo opportunities may be provided during the meeting for public relations’ purposes.

9. MEETING VENUE FACILITIES

9.1 Host Economy Secretariat

A Host Economy Secretariat office should be established with a list of persons for policy, logistical and administrative matters (accommodation, accreditation, meeting room reservations, documentation, information and communications technology, media arrangements, transportation, facilities and so forth). The location and operating hours of the Host Economy Secretariat offices should be stated in the administrative circular and delegate handbook. The office should be equipped with basic furniture, equipment, telephone, fax machine, computers, printers and stationery.

Where possible, the plenary meeting room(s), small meeting room(s) and Host Economy Secretariat office are expected to be located on the same floor and in close proximity. Information on meeting rooms for different subgroups or activities should be provided by the host economy in the Administrative Circular.

9.2 Common Delegation Room

It is customary that a Common Delegation Room be provided, offering the following services: an ample number of computers with high-speed Internet connection, an ample number of laser printers, a high speed copying machine with sorter, pigeon holes for the distribution of documents to member economies, the APEC Secretariat, ABAC and the official Observer delegations and basic stationery items. Fax and telephones for local/national calls should ideally be provided. For the Ministerial Meetings, it is customary for the hosts to provide a Press Centre.

9.3 Member Economy Delegation Rooms

For Ministerial Meetings, each member economy’s delegation may request a delegation room with basic furniture, equipment, telephone, fax machine, computers and printers. The costs of delegation offices and equipment are generally borne by the individual delegations. On request, rooms for bilateral meetings will be designated and are usually made available on a first-come first-served basis as required. The name of the Conference Secretariat contact person should be indicated in the Administrative Circular for booking purposes.

For Ministerial Meetings, a list of delegation rooms should be provided to all delegations as the information becomes available. Requirements for room space, basic office equipment and billing arrangements for the rooms need to be conveyed to the delegations in the Administrative Circular.

Delegations may wish to arrange for their own furniture and equipment. If delegations wish to do so, they should inform the host economy in advance. Delivery arrangements for economies' delegation rooms need to be explained in the Administrative Circular.

9.4 Registration Desk (Credentials)

Prior to the commencement of the meeting, a registration desk should be set up in the Conference Centre/venue, staffed by the host economy's Conference Secretariat staff. During registration, identification badges or credentials (with the title of the meeting, names of the delegation and individual participant and photograph), agenda and program papers, a participant registration form (to be returned), and other relevant literature should be given to the registered participants. Adequate staff, time and space is needed for delegate registration prior to the meeting commencement, to ensure there are no unnecessary delays.

9.4.1 Late Registration and Accreditation

A set of procedures for late registration should be set up, including information on the location, telephone number and operating hours of the registration area. This information should also be part of the Administrative Circular. In case a delegate has not registered on-line by the deadline or the required information has not been completely provided with her/his on-line registration, the DLO is usually requested to accompany the delegate to the Accreditation Desk to verify his participation at the meeting.

9.5 Information Desk/Services

Information counters to assist delegates obtain information pertinent to the APEC meeting should be established and information on their location should be included in the Administrative Circular.

9.6 Meeting Room Requirements

9.6.1 Plenary, Bilateral and Small Groups

The host economy is responsible for the arrangements and cost of suitable meeting room(s) and morning and afternoon refreshments. In addition to the plenary meeting room/s, it is useful to have small meeting rooms available to accommodate smaller drafting groups or special issue groups as required. The host economy is responsible for the arrangements and cost of the plenary meeting room(s), the small group meeting rooms, a conference secretariat room, the conference support staff and conference equipment (computer work stations, photocopying machines, printers, etc.).

It is likely to be necessary for the meeting rooms to be available beyond normal working hours. The Conference Secretariat should ideally be open the day before the meeting and stay open from early each morning to late each evening to meet delegations' requirements. Conference Secretariat staff are also needed outside of normal office hours to help in the preparation of report(s) and other matters. Often late night work is required and staff of the Host Economy Secretariat are expected to be aware of this and able to provide the necessary assistance as required.

If at all possible, the plenary meeting room(s), small meeting room(s) and Host Economy Secretariat office are expected to be located on the same floor and in close proximity. Information on meeting rooms for different subgroups or activities should be provided by the host economy in the Administrative Circular before or on arrival.

9.6.2 Equipment

- Microphones - To facilitate the smooth running of the meeting, the public address system in the plenary rooms should be in good condition. Microphones should be installed at the conference table, one for the Chair and preferably one per every two participants at the table, or at least one per every two neighbouring delegations.

- LCD projector, screen and laser pointer - should be available in meeting rooms. If requested, slide projector equipment, overhead projector and white boards should also be provided.
- Power (electricity) connections – This should be provided at the head table along with internet access for the Chair, his assistant, APEC Secretariat and invited guests. Adequate power connections should also be provided along the sides of walls in the meeting rooms to allow delegates to recharge their notebooks/laptops when needed.
- Delegates usually bring their own notebook computers and may request additional power outlets and/or Local Area Network (LAN) cables or wireless internet connections. This is up to the discretion of the host economy. However, it is advisable to request that delegates' notebook computers be registered and checked for viruses and updated anti-virus programs prior to plugging into the LAN.
- Where possible, sufficient wireless LAN access points should be made available to support up to 100 meeting participants, and 250 wireless devices. These should be provided throughout the premises (i.e. meeting rooms, offices, cybercafés, press center etc). The wireless LAN provided should meet the following standards:
 - The wireless LAN capacity for each meeting room and work area should be equal to the capacity of the room (i.e., assume every conference participant and support staff may wish to connect a laptop, smart phone and PDA at the same time);
 - The wireless LAN should be 802.11a, b, g, n (on both 2.4 and 5.2 GHz band) and Wi-Fi compliant;
 - The access points should support common encryption protocols (e.g. WEP, WPA, WPA2);
 - The target average ping response time from Notebook PCs to the gateway should not exceed twenty (20) milliseconds during normal load conditions;
 - The target average throughput for each laptop should be three (3) Mbps or above;
 - The Wireless access points should be centrally controlled to allow rapid, if possible auto, reconfiguration of the access points in order to adapt to changing load conditions in the conference rooms, and to block individual laptops in case of viruses.
- Reproduction of papers – Despite encouraging participants to bring adequate copies of papers they wish to circulate, or to circulate them in advance of the meeting, there might still be considerable demands for copying. The requirement for copying can be reduced by limiting the number of copies to each delegation or utilising innovative solutions such as the Less Paper Meeting System. For the latter, details may be obtained from the APEC Secretariat.

9.6.3 Seating

APEC meetings usually use a “hollow circular, oval, rectangle or square” for seating depending on the shape of the meeting room and the number of participants.

Plenary meetings usually allow for at least 2 seats at the table for each delegation present, two seats for the chair, one or two seats for the APEC Secretariat depending on who attends, one seat for each invited representative of other APEC fora, one seat for ABAC, 'Observers' (ASEAN Secretariat, PECC and PIF) 'approved guest' and invited speaker(s). Plenty of additional seating is required around the room behind delegation table seating to enable additional delegation members to sit close to delegation members at the table.

For Ministerial Meetings, there would be, at least, three seats for the chair, two seats for each APEC member economy and the APEC Secretariat, and one seat for ABAC and for each Official Observer at the table.

The seating of members around the table should be in the following APEC order:

Australia
 Brunei Darussalam
 Canada
 Chile
 People's Republic of China (China also acceptable)
 Hong Kong, China
 Indonesia
 Japan

Republic of Korea
 Malaysia
 Mexico
 New Zealand
 Papua New Guinea
 Peru
 Republic of The Philippines (Philippines also acceptable)
 Russian Federation (Russia also acceptable)
 Singapore
 Chinese Taipei
 Thailand
 United States of America (USA or United States also acceptable)
 Viet Nam

 Representatives of APEC Fora

 ABAC
 Observers – ASEAN, PECC, PIF

The Chair of the meeting should sit at the head of the table behind the nameplate of Chair. It is customary for the APEC Secretariat to be seated on the immediate right of the Chair. To facilitate dialogue among APEC member economies, it is desirable to have all other participants (invited representatives of other APEC fora, if any, ABAC, followed by official Observers and approved guests seated immediately after the last economy, Viet Nam. Invited speakers often sit on the left of the Chair at the head of the table for their agenda items. For details on various seating arrangements, please refer to the sample-illustrations for APEC meetings at **Annex C**. The actual shape of the table (hollow circular, oval, rectangle or square) is subject to the shape of the meeting rooms.

If absentees are expected in advance of the meeting, meeting organisers should ideally remove empty seats and nameplates to allow for better seating arrangements for those present at the meeting and for overall meeting efficiency.

(Sample-Illustration of Seating Arrangement for APEC Meetings)

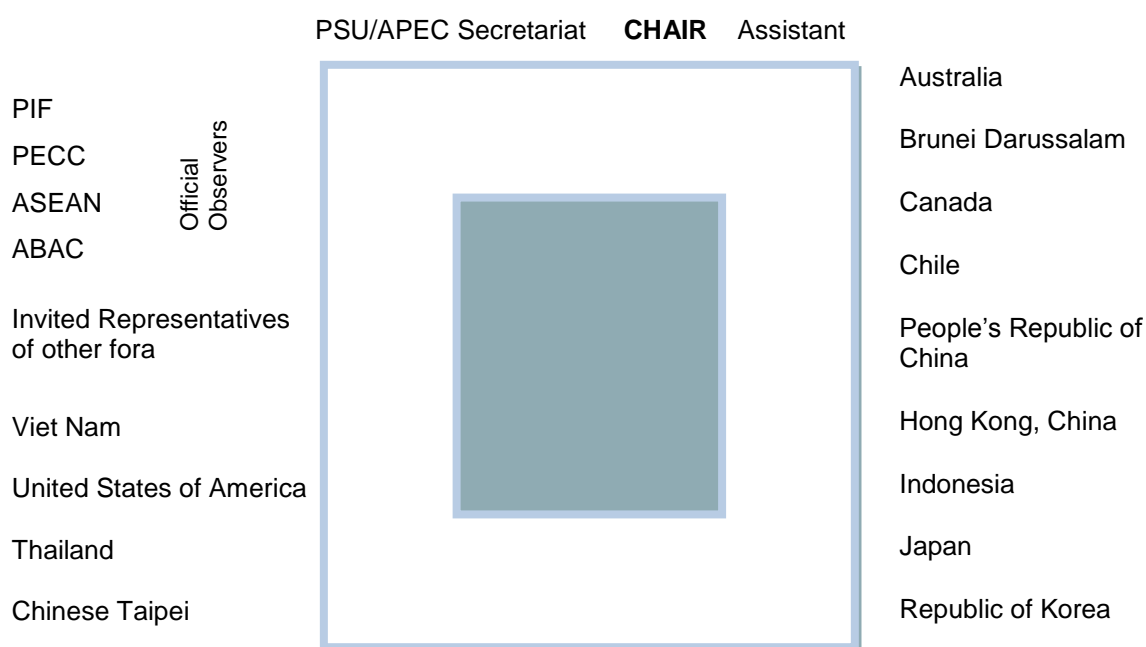

Singapore
Russian Federation
Republic of
Philippines
Peru
Papua New Guinea
New Zealand
Mexico
Malaysia

* Other Participants include approved guests (if any).

9.6.4 Nameplates

Nameplates should be available for the APEC members, APEC Secretariat, Committee Chairs (Co-Chair or Deputy Chair), ABAC, APEC Observers, invited speakers and any approved guests. Nameplates should also be available for any invited Chair/s from SOM, Committees or groups, e.g. CTI Chair addressing a sub-fora meeting. With reference to signs of identification placed on the table, the name of the economy only should be used at all meetings. Under the current arrangements, any approved “guest” participant has a lesser status than the official Observers.

9.7 Bilateral Room Requirements

The host economy is responsible for the arrangement and cost of suitable bilateral meeting room(s) or small meeting rooms to accommodate smaller drafting groups or special issue groups as required. It would be helpful if the host institutes a booking process for bilateral rooms to ensure availability of such rooms when economies or groups require them.

Minimal or no equipment is needed for bilateral meetings. A suitable room size with a table and adequate number of chairs are the key items. At a minimum, glasses or bottles of water and paper and pens should be provided, similar to what is provided in APEC plenary meeting rooms.

9.8 Signage

Hosts should plan for appropriate and clear signage to display various instructions and information for delegates. These include signage indicating locations of certain venues, e.g. registration, meeting rooms, common delegation rooms, bilateral rooms, exhibition displays, and instruction manuals providing information on use of equipment like photocopiers, printers and connectivity instructions, etc. Signage may also be displayed at airports and on municipal roadways and streets to welcome APEC delegates and to inform the public about ongoing meetings.

Signage, backdrops and banners should display the APEC logo, the title and dates of the meeting. The APEC logo should be included on every sign which indicates an APEC meeting. Text must comply with the approved style and nomenclature guidelines. The names and logos of co-sponsoring organizations may appear on signage, banners and displays, as appropriate, as long as the sponsoring logo is smaller than the APEC logo.

The APEC Secretariat should be consulted before printing commences. The Secretariat reviews design and text for compliance to APEC publications guidelines and nomenclature. Changes, if any will not affect the material’s substance. The Host should provide text in English, the official APEC language, but can translate any signage, as appropriate. For further information, please refer to the [*APEC Logo Guidelines*](#).

9.9 Staffing – Conference Secretariat Staff

The Conference Secretariat staff are needed, at a minimum, to:

- handle registration of the delegates
- act as runners in the meeting room(s) to assist in distribution of documents, and undertake other duties as required (at least one)
- handle photocopying and document production (at least one)
- operate computers and printers (at least one)

- provide information on meeting activities, venues, timetables etc., as required
- provide delegates with meeting documentation and material
- provide technical assistance as required
- provide general support and other duties

9.10 Improving Efficiency of Meeting Arrangements

Paperless Meetings

This practice has been adopted by some APEC hosts in the past. They are typically easier to facilitate for stand-alone meetings. If a meeting host decides to hold a paperless meeting, then it needs to review well in advance the requirements to facilitate such meetings and to ensure that delegates are informed of this arrangement in the respective administrative circular.

Remote Participation

Hosts could consider the use of remote participation or access to meetings which would allow delegates to participate in APEC events without having to travel to the meeting venue. Remote participation involves either utilizing an interactive web conferencing solution or using a desk telephone to participate and watch the meeting through a webcasting centre solution and for speakers to deliver voice presentations. Certain considerations to factor in when using this option would be time zone differences, amount of available internet bandwidth for both host and delegates, and employing physical and hardware resources to facilitate the virtual discussions and/or recordings. Smaller meetings, workshops and seminars may likely benefit from this conferencing option. More details of this facility can be obtained from the APEC Secretariat.

Remote Listening

Hosts may also consider the use of remote listening services especially during instances of poor internet access or internet traffic congestion. Because of low-streaming audio bandwidth, this mode is also useful when remote participants experience limited internet bandwidth or can only use a traditional desk phone. Implementing the remote listening mode merely involves inactivating the video feature of the remote participation facility. More details of this tool can be obtained from the APEC Secretariat.

10. DOCUMENTATION

The APEC Secretariat has developed *Documentation Guidelines for Meeting Organizers* to ensure that APEC meeting documents are processed according to standard and captured completely to facilitate dissemination and archival. These guidelines are available on the APEC Secretariat website.

The Documentation Centre is responsible for the reproduction and distribution of all official meeting documents. A complete set of documents should be collected by the Meeting Organiser in electronic copy and given to the APEC Secretariat Director (Program) before he/she departs from the meeting venue.

All delegations are encouraged to circulate documents by e-mail or the APEC Information Management Portal (AIMP).

In brief, the following key requirements should be observed when submitting meeting papers to APEC meetings:

- All documents must be submitted in electronic copy.
- All documents requiring a decision by the group or “for consideration” should be submitted to the relevant Director (Program) and circulated to all members 10 days before the meeting. This will allow papers to be reviewed in advance of meetings

While the above are general guidelines to be observed by meeting organizers, there are also specific requirements applicable to the submission of meeting papers to other fora, SOM and Ministerial meetings:

10.1 Submission of Papers for SOM Meetings

- All documents are submitted directly to the host Documentation Centre with a copy to the SOM Chair's Office
- All SOM documents must be accompanied by a one-page Executive Summary, outlining decision points and/or deliberations required from the SOM;

10.2 Submission of Papers for Other Fora Meetings

- Documents for all other meetings are to be submitted in directly to the APEC Secretariat's Director (Program) supporting the fora;
- The Director (Program) supporting the fora will contact the fora members directly with instructions on deadlines and formats for the submission of meeting papers under their responsibility; and

10.3 Submission of Papers for Ministerial Meetings

- Documents to be submitted to the relevant APEC Secretariat Director (Program) with a copy to the office of the Minister who chairs the meeting.

For further information about documentation requirements please contact the relevant APEC Secretariat Program Directors or the Information Manager, at e-mail *info@apcc.org*.

10.4 Classification of Meeting Papers

All final documents from APEC meetings are made accessible to the public. In addition, other documents may be made public, on a consensus basis, by the originating fora through the discussion and conclusion of the document classification list which is tabled for consideration at all meetings.

10.5 List of Participants

The list of participants should normally contain participants' names, titles, organisation/department, address, fax and phone numbers, and e-mail addresses in protocol order for each delegation. The order of the list should be APEC members, APEC Secretariat, ABAC, APEC official Observers and guests, if any. The process of drawing up the list of participants can be greatly assisted if APEC contact points provide this information on their initial registration material. The host economy can then draw up a draft list of participants before participants arrive. The draft can be amended and circulated to the participants after registration. Once comments and corrections are received, a final list of participants can be prepared for circulation.

11. DELEGATE SERVICES

11.1 Host Liaison Officers

The Liaison Officer (LO) is the main channel of communication between the Task Force and Economy delegation on logistical matters such as providing registration information, program guidance and, all documentation as well as informing ministerial staff about the administrative and protocol arrangements. During the meetings, liaison officers serve as the eyes and ears of the Task Force and a first tier of problem solvers for economies. Liaison officers might not know the answer to a problem but they need to know where to find a solution, quickly.

APEC practice is for the host economy to provide Liaison Officers (LOs) to Senior Officials and heads of delegations during SOM, Ministers (or their designate) and to Leaders during AELM. In addition, LOs' should be provided for the Executive Director of the APEC Secretariat, ABAC and Heads of Observer delegations (ASEAN, PECC and PIF).

For Ministerial Meetings, one liaison officer is considered appropriate for each Minister. This designation avoids confusion in situations where an economy may send more than the specific APEC ministers (Ministers responsible for Trade and/or Foreign Affairs). For the Leaders', the following LOs' would be appropriate to meet the differing needs of each economy: Leader, Leader's spouse, if attending, two APEC ministers – Trade and Foreign Affairs, if attending, and a Delegation Liaison Officer.

11.2 Member Economy Delegation Liaison Officers

A Delegation Liaison Officer (DLO) who serves as the main channel of communication between the Host Economy and delegation should be appointed for each SOM and Ministerial meeting by the following delegations:

- all APEC Member Economies;
- APEC Secretariat;
- APEC Business Advisory Council (ABAC)
- APEC Official Observers:
 - Association of Southeast Asian Nations (ASEAN) Secretariat;
 - Pacific Economic Cooperation Council (PECC) Secretariat; and
 - Pacific Islands Forum (PIF) Secretariat

Delegations should forward the name and contact details of their DLO to the host as stipulated in the administrative circular.

12. ARRIVAL AND ENTRY FORMALITIES

12.1 Visas

All delegates should ensure that they possess valid passports prior to embarking on travel. Delegates from certain economies require visas to enter the host country and are responsible for arranging their visas, if required. The administrative circular usually provides a listing of visa requirements or waivers (if applicable) for each economy. If in doubt, delegates should check with the nearest diplomatic or consular representation for information on visa requirements prior to finalizing travel arrangements.

12.2 Airport Facilitation / Welcome Desk / APEC Lanes

Depending on the complexity of airport arrival formalities and possible language difficulties for some APEC members, it is useful to consider operating a "welcome desk" at the airport for participants on arrival. For Ministerial Meetings, it is highly recommended to do this. A small airport reception team of greeters and transport coordinators can assist in facilitating the arrival and departure process for delegates, baggage handling and transportation movements.

Host economies have in the past, worked with immigration service at airports to provide special APEC lane/s to allow for "fast track" passenger processing for APEC visitors.

It is the responsibility of the host economy to determine whether it can provide transportation from and to the airport for delegates. If this is not provided, it is necessary to give clear advice on airport entry formalities and on obtaining transport to and from the hotel in the Administrative Circular or in the advance information provided by the host economy.

For Ministerial meetings, it is customary that all Ministers and Heads of Delegation (including APEC Secretariat, ABAC, ASEAN Secretariat, PECC and PIF) are provided with a car and driver and all local transportation costs are covered.

13. CONTACT POINTS

Information on all APEC contact points is available from the APEC Secretariat. Additionally, the [APEC Information Management Portal \(AIMP\)](#) allows APEC members to access the responsible fora/working group site to which they have access to update their contact point details directly.

14. CHAIR/LEAD SHEPHERD

The role of the Chair/Lead Shepherd is to coordinate the schedule and chair meetings, lead, guide and summarize the discussion of the fora, group, subgroup or ministerial meeting. The Chair also oversees the development of activities ensuring that the Working Group and other APEC fora in responding to Leaders and Ministers' priorities, coordinate with other APEC bodies, enhance the quality of project proposals with well-defined outcomes and acts as the spokesperson for the relevant Working Group or APEC fora.

As such, the Chair is not representing his/her own economy but is leading the APEC specific forum. The Chair and the 21 member economies follow the prescribed APEC seating order during plenary meetings. In Working Group Meetings, if the Host Economy is acting as the Chair, it would be useful to arrange for pre-meeting discussions with the Working Group Chair/Lead Shepherd and the APEC Secretariat to finalize agenda items and scheduling of each item, to determine meeting protocols and procedures and outline expectations of the Chair and the Lead Shepherd.

15. APEC SECRETARIAT

The APEC Secretariat generally attends all APEC fora meetings and provides advice and technical assistance on APEC procedures, documentation, preparation of Summary Records and other issues, as required. Office space for the APEC Secretariat should be provided and paid for by the host economy. The APEC Secretariat will send information to the host economy on required office space and the basic furniture, equipment (computers, printer, fax, stationery etc.) prior to the meeting. The hosts normally provide the equipment to the APEC Secretariat free of charge.

The level of policy and logistical support provided by the APEC Secretariat to the individual APEC Year host economies, including for Sectoral Ministerial Meetings, and logistical requirements for the Secretariat's Office at Senior Officials Meetings and related meetings appears as **Annex A and B** respectively.

At the Ministerial Meetings (including the Finance Ministerial Meeting), it is customary that the Executive Director and the Director (Program) responsible for the Ministerial Meeting participate. The Executive Director is customarily accorded treatment and courtesies equivalent to Ministers and be provided with an opportunity to give a short presentation on APEC developments and recommendations affecting the issues under discussion.

At working group meetings, the APEC Secretariat normally provides only one person to provide support, general policy advice, directives of APEC SOM and current APEC developments to the Chair and working group members throughout the meeting. Special invitations can be extended to the Executive Director and members of the Secretariat's specialist staff such as those from Communications, Finance or Project Management. The APEC Secretariat is happy to work closely at all times with the host's Conference Secretariat staff in ensuring the success of the meeting. The APEC Secretariat has contact lists for all the different APEC fora, the chairs and convenors of the Committees, sub-committees and the APEC Observers. The Secretariat is also able to provide value-added services in the communications and outreach area.

The APEC Secretariat also participates in and provides technical support to the APEC Business Advisory Committee (ABAC) meetings. The Executive Director, the Director (Program) and other specialist staff such as those from Communications usually attend. The APEC Secretariat provides regular updates on work done by APEC fora in response to ABAC's recommendations for a given year. The APEC Secretariat's Communications' unit provides advice and identifies ABAC's key messages to integrate with the APEC process.

15.1 Communications, Public Affairs and Outreach by APEC Secretariat

New initiatives, events, publications and projects are of interest to many audiences within and outside the APEC process. The APEC Secretariat Communications and Public Affairs Unit can effectively promote the work of each forum to the media, business, government officials and other key target audiences. The team also provides publications advice and production services, as well as advice on APEC documentation requirements.

A few specific examples of available assistance are:

Media Support

Just about all APEC events and issues are of interest to the wide range of recipients of official APEC news. This includes major news outlets such as CNN, industry publications and the growing number of direct APEC News recipients. The Secretariat distributes news releases and media advisories that focus on the APEC agenda and that draw attention to the relevance and

outcomes of APEC events, issues and meetings. As such, early advice about upcoming events is needed so that we can highlight them on the APEC website and alert international media contacts.

The Communications and Public Affairs Unit will prepare a draft news release should there be an opportunity to tell a story. The relevant Fora Chair or official will clear the draft material before the media release is distributed.

The Communications and Public Affairs Unit drafts news releases to cover Senior Officials' Meetings and Ministerial Meetings. The relevant Chair or official will clear the draft material before the news release is distributed.

Holding News Conferences

News conferences are held after each ministerial meeting. Participants generally include the ministers and the APEC Secretariat Executive Director. Seating arrangements are generally made in alphabetical order. The Chair is flanked by the incoming and outgoing hosts and the APEC Secretariat Executive Director. The Communications Public Affairs Unit is able to provide advice on best practices for news conferences and media events, suggest seating arrangements and explain matters of protocol.

The Communications Public Affairs Unit can also organise and liaise with featured speakers, advise as to form and delivery, and moderate/emcee press conferences. A News Conference Seating Arrangement plan can be found in **Annex C**.

International Media Center

The host economy facilitates media accreditation for the attendance of international media at APEC events and the appropriate technical setup and venue for the International Media Center.

Delivery of Photography, Video and Statements

The host economy is responsible for arranging host broadcasters and photographers. Host generated materials such as photographs, videos and news releases should be delivered promptly to the APEC Secretariat. Declarations and Statements should be delivered as soon as they are endorsed in the meeting for upload on the APEC website and distribution. It is recommended that the host set up an online tool or facility to high resolution images and video to be shared directly with news organizations.

Use of APEC Trade Marks: APEC Logo and Acronym

The APEC Logo and all outputs from APEC projects are copyrighted. The APEC Secretariat is the custodian of APEC's identity and its products and monitors the use of the APEC logo. More details can be found in the [APEC Intellectual Property Policy](#).

In brief, the APEC logo of globe-shaped in green blue and white was adopted in 1991 and is the property of the APEC Secretariat. The use of this logo by member economies is allowed but is subject to the conditions as prescribed in the [APEC Logo Guidelines](#) which can be downloaded from the APEC Secretariat's website.

If members, fora and organizations would like to reproduce the APEC trade marks for APEC events or to produce publications and reports, they should write to the Secretariat for permission. This is to record and ensure that the marks are used correctly. To ensure that the APEC logo is reproduced correctly in event materials (e.g. banners, name tags) or reports (e.g. proceedings, CD-Roms), organizers and authors should adhere to the visual guidelines and acronym shown as well as the colour guides and dimensional requirements stated in the Guidebook. Organizers should forward their draft designs that include the APEC trademarks to the Secretariat for review.

For the right to use the APEC trade marks for a specific purpose, members or organizations will require licenses. Some examples include the *Trade Mark License Agreement for Organizations*, the *Trade Mark License Agreement for Economies* and the *Copyright License Agreement*. Please consult the responsible Director (Program) or contact info@apec.org to obtain the logo guidelines and files.

APEC's Tagline

APEC's tagline - *Advancing Free Trade for Asia-Pacific Prosperity* - is used in conjunction with the APEC Logo. More details can be found in [The APEC Tagline Guidelines](#).

APEC Websites

Working Groups or event organizers may set up separate websites (APEC-Satellite Websites) for their groups or events. Organizers and their web managers should refer to the [APEC Website Guidelines](#). This guidebook provides information on general principles, web design and style on how the APEC logo is displayed, design considerations, copyright issues, use of "APEC.ORG" sub-domain name. For assistance, please contact the Web Manager at info@apec.org.

For more information, please refer to the [APEC Website Guidelines](#). Please fill up the [APEC Satellite Website Review form](#) and email website@apec.org if you have a new Satellite Website for review. The Web Manager from the APEC Secretariat will contact you once the form is received.

Social Media

To effectively communicate information about APEC and create awareness and understanding the host's priorities, social media offers opportunities for people to gather in online communities to create, share and consume content. More information can be found in the [Social Media Guidelines](#).

Information Disclosure

APEC operates by consensus and it needs space to consider and debate issues away from public scrutiny in order to develop that consensus. For the deliberative process to function optimally, it is necessary to safeguard the free and candid exchange of ideas.

Therefore, while APEC makes publicly available summary reports and other documents classified for public release by the originating fora, meeting participants are expected to display sensitivity in disclosing information to the public exchanged during the course of its deliberations.

16. SECURITY ARRANGEMENTS

As part of the security arrangements and as part of the conditions of entry to meeting venues, delegates may be subject to various levels of screening and access control. All relevant staff and delegates will be subjected to an accreditation process, and issued with an accreditation pass. Accredited personnel are required to wear their accreditation credentials (accreditation pass or lapel pin) in designated venues and zones.

All participants should wear their identification badges or lapel pins and where applicable, their access overpasses while at the meeting venue and at all social functions. Security arrangements should be explained in the Administrative Circular.

In order to provide adequate security and ensure the safety of all events, varying levels of screening may occur at each event. Screening may consist of visual and electronic checks of accreditation passes and electronic or physical searching of bags and other belongings.

17. TRANSPORT

It is optional whether the host economy arranges and pays for the travel of the delegates from the airport to the hotel and return. Shuttle bus transport from hotel(s) to the meeting venue should be arranged and clear directions given on timetables, pickup and delivery points, frequency of trips and expected time of arrival at hotel or at the meeting venue. If the meeting is held in the hotel where the delegates are staying, this may not be necessary. This information and other information about taxis or other means of local transportation should be provided in the Administrative Circular and in the Delegate's Handbook before or on arrival.

18. PRESS ACCREDITATION, BRIEFINGS AND COVERAGE

Press accreditation and Briefings are the responsibility of the host economy. For Ministerial Meetings, a Press Centre should be set up and information on its location, operating hours, services (press conference rooms and press briefing rooms), process of accreditation, process for requests for interviews should be provided in the Administrative Circular and Delegate's Handbook.

For Ministerial meetings, the APEC Secretariat is prepared to broadcast press advisories to a global network of news organisations and to place the pre-meeting advisories and concluding statements on the *APEC website*. The APEC Secretariat is also prepared to support all APEC meetings with basic APEC information such as the Update of Activities brochure and other relevant outreach material at no cost to the host economy. The host economy shall facilitate the duty-free importation of such materials.

19. INTERPRETATION SERVICES

English is the official language for all APEC meetings. Interpretation services are usually available for ministerial and AELM meetings only. Economies should arrange and accredit their own interpreters for both simultaneous and whispering interpretation. Economies should ensure their interpreters are experienced in simultaneous conference interpretation.

Information on the location of the interpretation services, mode of accessing them, the use, etc. should be included in the Administrative Circular and at the Conference Secretariat on arrival. It has been the practice for the costs of the interpretation infrastructure (booth, electronic equipment etc.) to be paid by the host economy and the cost of the interpreters (fees, expenses etc.) to be paid by the economy requiring the interpretation services.

20. MEDICAL SERVICES

Information on the provision of medical services should be provided in the Administrative Circular and in the Delegate's Handbook. This may not be necessary for Working Group meetings.

Medical clinics should ideally be staffed by health care professionals to provide first aid, primary health care treatment and a referral to further treatment free of charge. Should delegates require treatment by a specialist medical doctor or hospital, the cost of these services is the responsibility of the delegate.

21. HOSPITALITY

It is an established convention to offer certain hospitality events in conjunction with certain meetings. While it is entirely up to host economies to decide how to show their hospitality, it is helpful to know the established patterns. Host economies often choose to provide working lunches during the meeting and host a dinner and/or reception for participants (sometimes in conjunction with local business sector representatives). Occasions such as dinners and luncheons, for example, provide important opportunities for delegates to continue informal discussion of the APEC agenda or to conduct impromptu bilaterals.

Other hospitality items include a "Spouses" program at ministerial and higher level meetings, small gifts for delegates, wine-tasting events, discounted entry into places of interest, and so on. It is largely through these hospitality events and activities that the host economy is able to "showcase" aspects of its culture, produce, and people to Leaders and their delegations.

For official occasions to which additional economy representatives are invited, e.g. plus 6, the APEC Secretariat should receive equivalent number of invitations.

It is an established convention to arrange for a group photograph to be taken, (SOMs, SFOM, Ministerials, MRT, FMM, AMM, AELM) and some photos during various activities, and have these as a souvenir or have them available for sale to participants. Usually, the host economy sends a copy of the photo to the APEC Secretariat for archival and public relations' purposes. For the AELM, the photograph protocol order follows the Troika format – economies in alphabetical left to

right arrangement with the troika in the centre (the host flanked by the previous host on the right and the incoming host on the left positioned in the middle of the first row). Hosts for other meetings can adopt this troika format as well.

Hosts should note the sensitivities on giving gifts to officials. If there is intent to provide such gifts, hosts are encouraged to provide items that are modest in value.

22. SPONSORS

Corporate sponsorship programs have become a potential source of funding to supplement the host government's budget in organizing APEC meetings throughout the year. As the APEC meeting agenda is largely in support of trade and investment liberalization and facilitation, the presence of corporate sponsors reflects the strong partnership that the host government has with its private sector. *APEC's Sponsorship Guidelines* help economies manage negotiation with corporate entities.

Unlike the sponsorship guidelines which govern the corporate sponsorship for Working Group meetings, the sponsorship program by the host economy is the responsibility of the host and is managed only for that year. Depending on the arrangement, this program is often planned as part of the Organizing Committee's activities to raise funds and in-kind contributions to support the logistical needs of the meetings. This includes basic hospitality such as souvenirs, stationary, delegates' handbook and bag, coffee breaks, welcome signboards, a privilege card for discounted shopping, etc. In some cases, corporate sponsors can also play a major role in providing logistic needs such as discounted airfares to meeting venues, limousine transportation, telecommunications equipment and hospitalities such as the welcome banquet, cultural and sightseeing programs for the delegates.

Some host economies have had elaborate schemes that classified the levels of sponsorship (Platinum, Gold, Silver, etc.) according to the amount of contribution. In return, the sponsors have received different levels of benefits in terms of the exposure of their trade mark or logo at the site of the meeting (but not in the meeting room), invitations to welcome receptions hosted for delegates, license to use the APEC Host logo (not the APEC logo) on their products during the year, and exclusive presence of the company's logo in public relations materials by the host economy.

23. THEMATIC FIELD TRIPS

Field trips are more commonly associated with Working Group Meetings, but occasions have arisen when field trips have been arranged for Ministerial Meetings. The host economy may consider arranging a field trip on the last day of the meeting. Since the field trip is usually considered as part of the meeting (some working groups even adopt summary conclusions of the meetings after the field trips), the host economy is expected to bear the relevant cost for the trip. Certain sub-fora and working groups also have the practice of organising field trips for their groups.

If a field trip is undertaken, the host economy is responsible for preparing the Program for participants and providing information on scheduling, venues and transportation.

Annex A

APEC Secretariat Support to the Host Economy

The APEC Secretariat is the core support mechanism of the APEC process. The Executive Director of the Secretariat is responsible to Senior Officials through the SOM Chair and manages the Secretariat in line with priorities established by Leaders' and Ministers' tasking directions to Senior Officials.

In general, the APEC Secretariat has provided the following support to APEC host economies, as Chair of both SOM and Ministerial Meetings in a given year.

SUPPORT TO MEETINGS

For APEC Ministerial Meeting (AMM):

- Provide comments on the draft agenda.
- Provide comments on the draft Joint Ministerial Statement.
- Provide advice to the Chair on various substantive and logistical matters before and during the meeting, including on participation, procedures, document numbering system, and meeting room arrangements.
- Provide recommendations on public access to meeting documents.
- Provide background documents on different issues.
- Provide draft papers on different issues, including the annual CTI, EC and ECOTECH Reports.
- Provide outlines of discussion after the AMM.

For relevant Sectoral Ministerial Meetings (SMM) to be held in the APEC Host Economy:-

- Provide comments on the draft agenda.
- Provide comments on the draft Ministerial Statement.
- Provide advice to the Chair on various substantive and logistical matters before and during meetings, including on participation, procedures, document numbering system, and meeting room arrangements.
- Provide recommendations on public access to meeting documents.
- Provide relevant background documents on different issues.
- Provide draft papers on different issues.

For Senior Officials Meetings (SOMs):

- Compile the annual Tasking Statement from the preceding year's AELM and AMM.
- Provide draft agendas.
- Provide detailed notes and draft Chair's Summary Record on a daily basis.
- Provide recommendations on public access to meeting documents.
- Provide advice to the SOM Chair on various substantive and logistical matters during meetings, including on participation, procedures, document numbering system, and meeting room arrangements.
- Provide background documents on different issues.
- Provide draft papers on different issues, as required.

For Fora Meetings (including Committees, CTI Sub-fora, Working Groups and Task Forces)

- Provide draft agenda.
- Provide draft summary conclusions after the meeting as mutually agreed between the Chair and APEC Secretariat.
- Provide advice to the Chair on various substantive and logistical matters during the meeting, including on participation, procedures, document numbering system, and meeting room arrangements.
- Provide recommendations on public access to meeting documents.
- Provide background documents on different issues

Other Meetings Held at the Margins of SOM

- Liaise with Convenors/Chairs of relevant APEC fora which meet at the margins of SOM.
- Advise SOM Chair of dates and meeting room requirements for these meetings.
- Provide support to the relevant meetings, as required by the Convenors/Chairs.

Media Support

- Implementation of the Communications and Outreach Strategy.
- Other support such as uploading press advisories concerning major APEC meetings to APEC Secretariat website, providing advice and assistance on media arrangements and information distribution to media.

Other Support

- Provide advice on any APEC related issues to SOM Chair.
- Provide support to the host economy for the submission of the IAP Peer Review process yearly project.
- Maintain and update contact details of SOM/Committees/Working Groups for use by the SOM Chair and provide liaison efforts between SOM Chair and APEC fora (as appropriate).
- Provide assistance on documentation process and procedures as required at SOM meetings.

Annex B

General Logistical Requirements for the APEC Secretariat at Meetings in the APEC Host Economy

- An accommodation block booking reserved at the meeting venue for all APEC Secretariat staff attending the meeting (inclusive of internet access to be included in accommodation tariff) which will be paid by APEC Secretariat. The room rate to be advised in advance.
- Equipment and furniture requirements and basic stationery supplies for APEC Secretariat Office.
- Transportation to be provided to the Executive Director according to courtesies extended to Heads of Member Economy Delegations and Head of Official Observer Delegations.
- One twelve-seat minibus or transportation option to be provided to the APEC Secretariat staff for transportation (whenever possible).
- Liaison officer and local volunteers to be provided to the APEC Secretariat delegation.
- Where access to meetings is limited to those with overpasses/access passes, the APEC Secretariat will be provided with overpasses/access passes as follows:
 - for SOM meetings, all Secretariat professional staff are to be provided with overpasses/access passes; In practice, this has been minimum 8 for ISOM, 10 for SOM plenaries.
 - for the AMM and Sectoral Ministerial Meetings, the Secretariat is to be provided with at least twice the amount of overpasses issued to member economies.
 - Access to the AELM Retreat will be provided to the APEC Secretariat Executive Director (ED) plus one.
- To facilitate contact between the host economy and the APEC Secretariat, 5 mobile phones whenever possible, could be provided to the APEC Secretariat delegation for use during the SOM meetings. Other Secretariat staff are generally issued with SIM cards which will be paid for by the Secretariat.
- For lunches and dinners hosted by SOM Chair, invitations typically include the Executive Director ED plus 2 staff.
- For official occasions to which additional economy representatives are invited, e.g. plus 6, APEC Secretariat would typically receive equivalent number of invitations
- Basic beverage items like a water dispenser, coffee/tea facilities, morning and afternoon tea breaks are typically provided.

Equipment and Furniture Requirements for APEC Secretariat Office at SOM/MRT/AMM/AELM Meetings

- A.** It is customary that hosts provide a working office to accommodate a 20-25 people Secretariat delegation, offering the following services: Sufficient basic furniture, 2 computers installed with English software, latest Microsoft and antivirus programs and high-speed internet connection; 2 laser printers, a high speed copying machine with sorter; a "pigeon hole" cabinet for the distribution of documents to Secretariat personnel; approximately 15 LAN lines and configuration of all APEC Secretariat Notebook computers and/or wireless access, sufficient electrical outlets/extension boards and a suitable amount of basic stationery items. Fax and telephones for local/national calls, wastepaper bins, a whiteboard and adequate lighting should ideally also be provided. An itemized list of room and equipment requirements can be provided by the APEC Secretariat.
- B.** A separate working office for the Executive Director is traditionally provided, equipped similarly with a computer with high-speed internet access, printer and telephone, basic stationery items and sufficient furniture to host a small meeting or bilateral (table with 6-8 chairs, sofa and coffee table). Coffee/tea and refreshments are generally appreciated.
- C.** In order to provide note-taking support to the host during SOM plenary sessions, a separate desk to seat 4 (four) Secretariat staff, electrical outlets/extension boards and internet access should be made available in the SOM meeting rooms.



Asia-Pacific
Economic Cooperation



Annex C

Sample Seating Layouts for APEC Meetings

Workshop - Theatre Setup

Invited Guests

Assistant
Chair

Chair

APEC
Secretariat PD

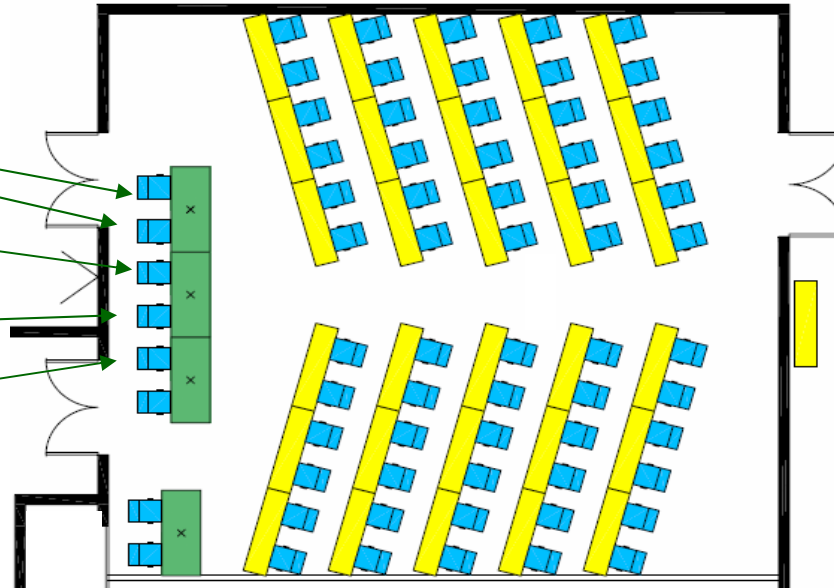

Workshop - Classroom Setup

Invited
Guests

Assistant
Chair

Chair

APEC
Secretariat PD

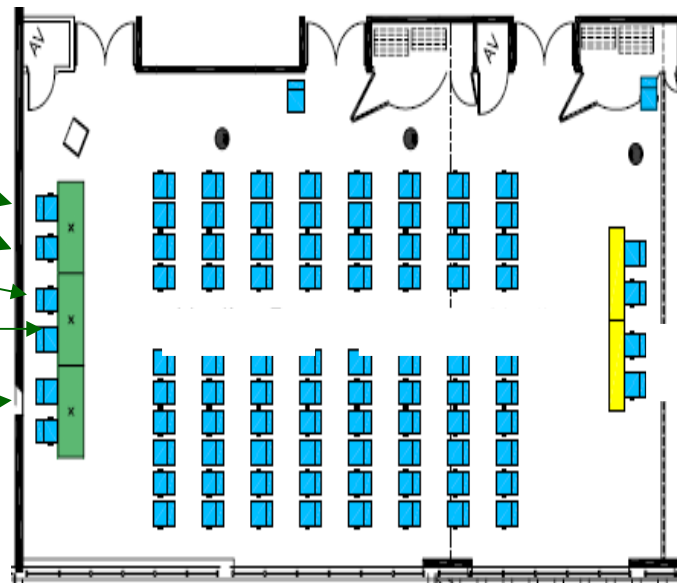

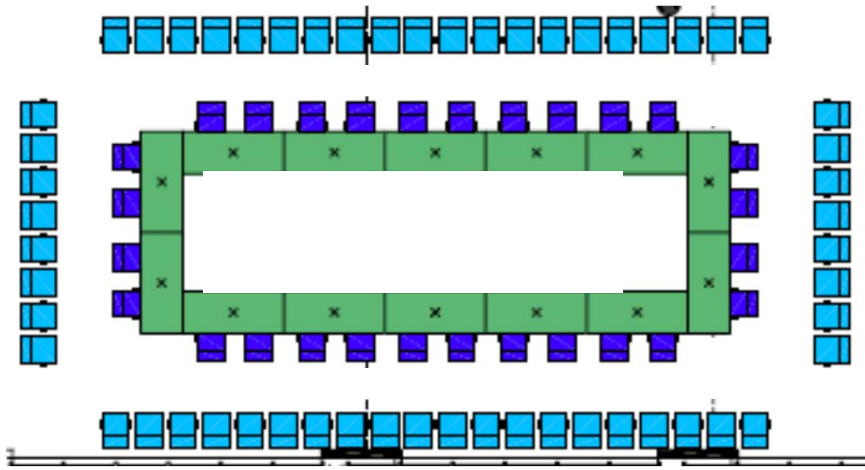

Sample Training Setup – No Name Plates Required

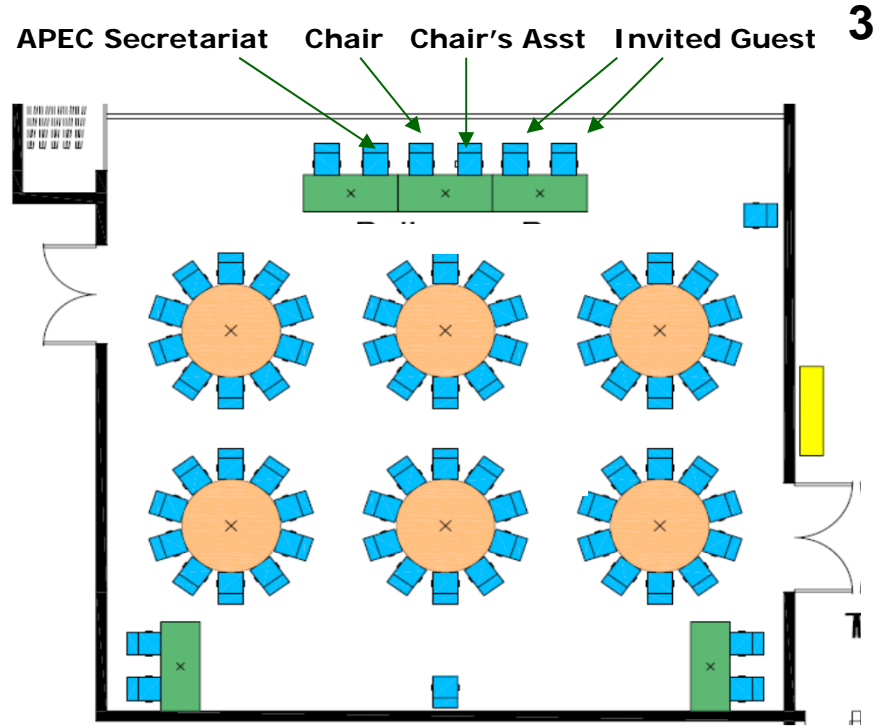

Sample Workshop – Round Table Setup

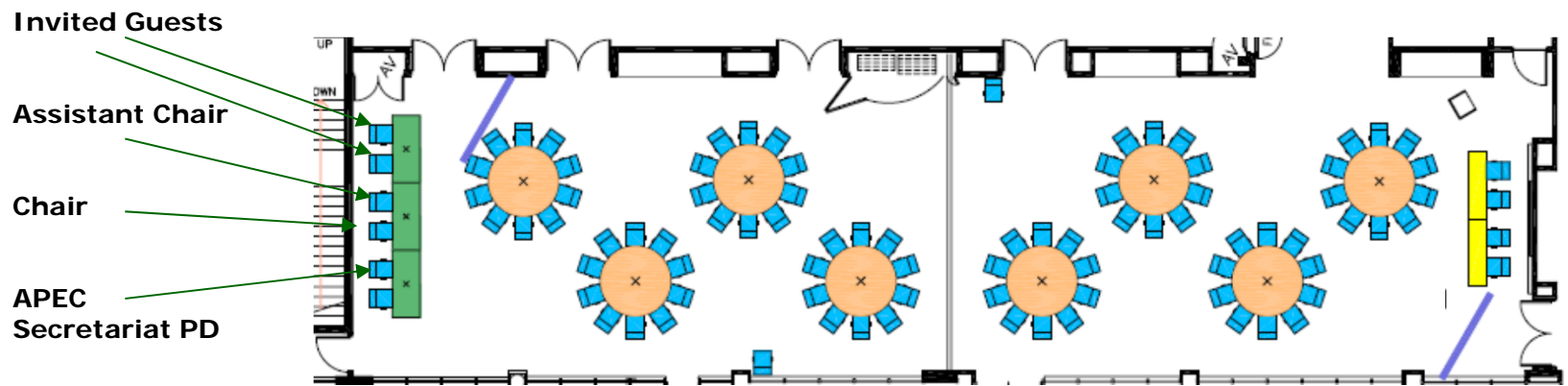

Sample Breakout Session

Singapore Chinese Taipei Thailand USA Viet Nam ABAC Observers (if any) – ASEAN, PECC, PIF

Hollow Square Fora/Working Group Plenary Setup

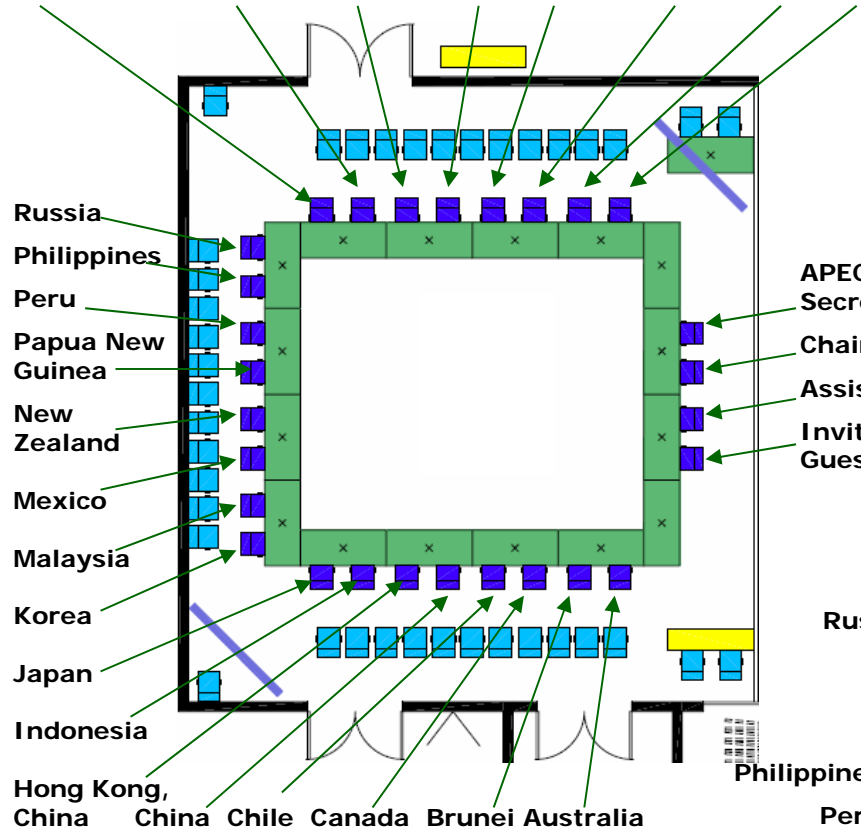

Russia Singapore Chinese Taipei Thailand USA Viet Nam ABAC Observers

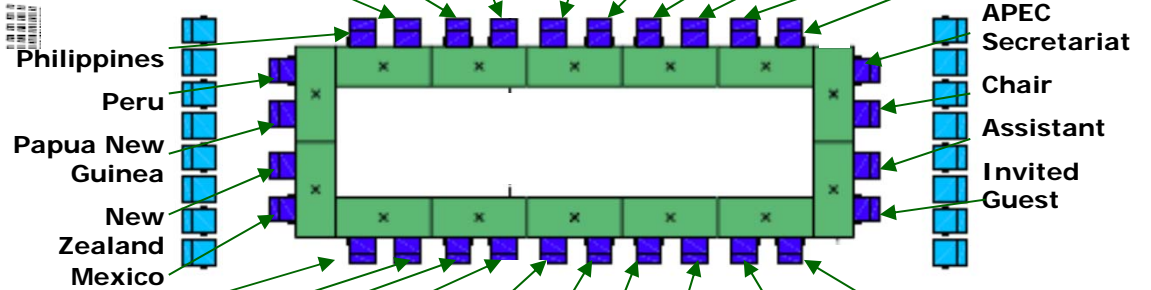

Malaysia Korea Japan Indonesia Hong Kong, China China Chile Canada Brunei Darussalam Australia

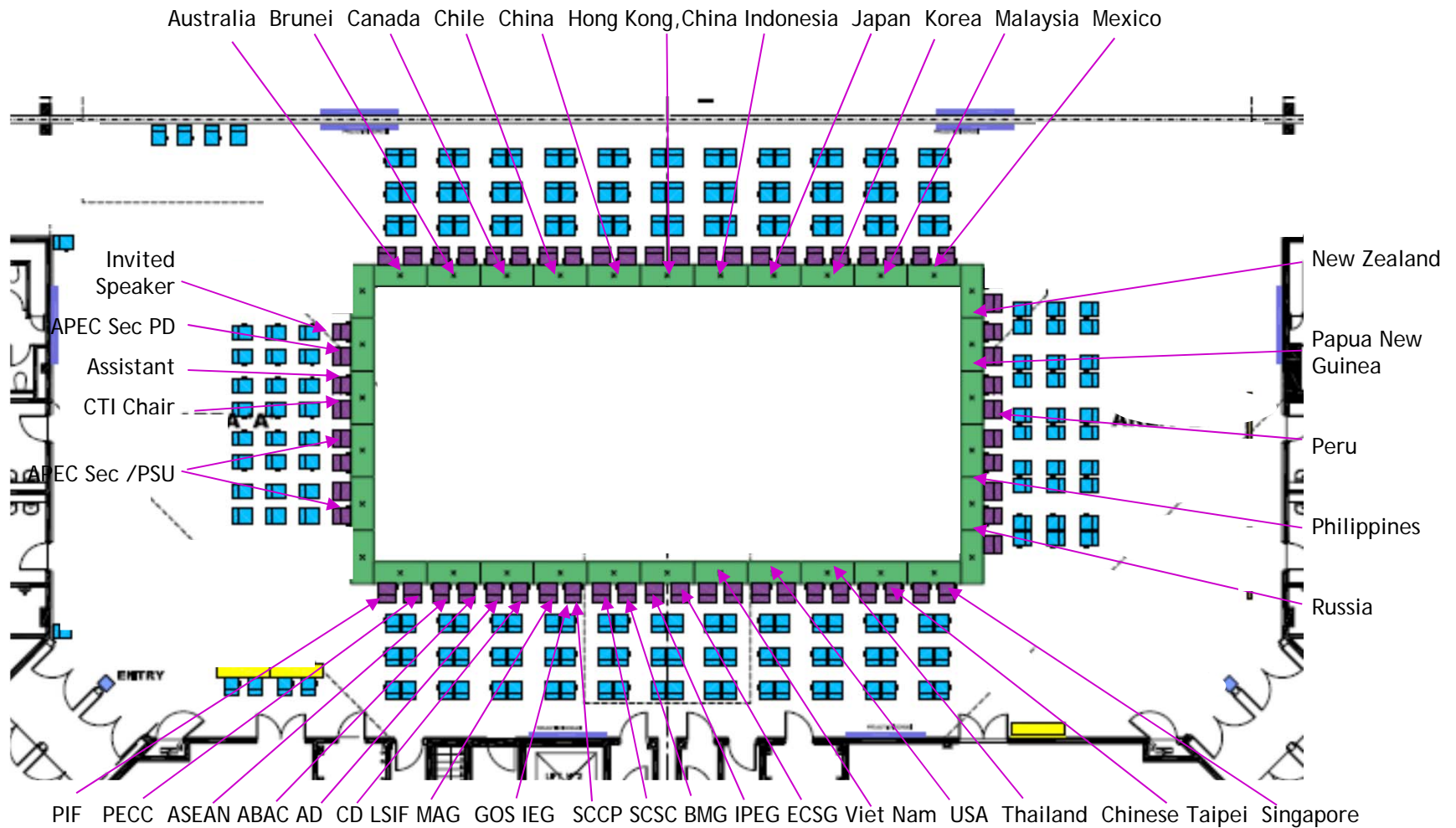

Committee on Trade and Investment (CTI) Plenary

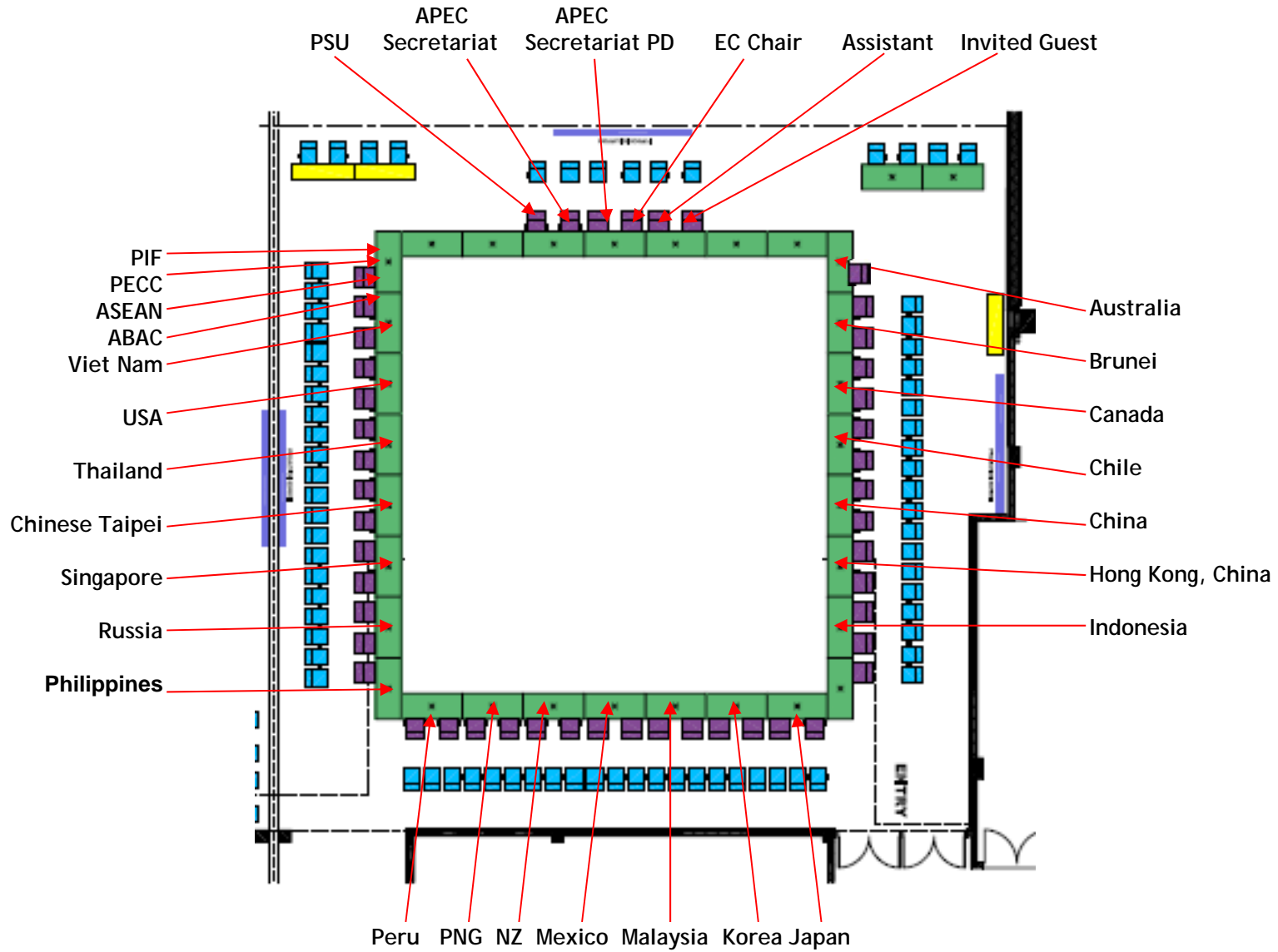

Economic Committee (EC) Plenary

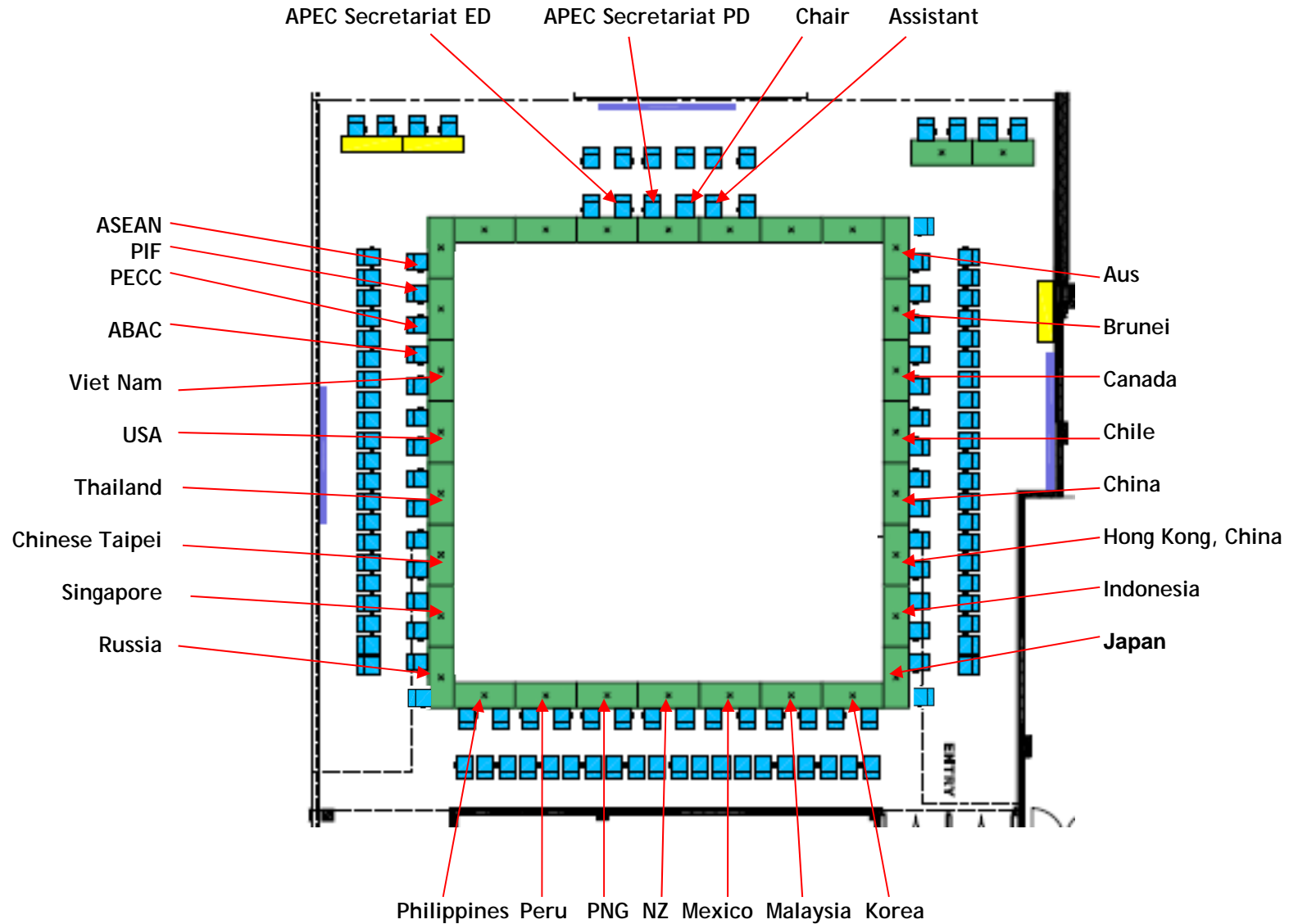

SOM Steering Committee on ECOTECH (SCE) Plenary

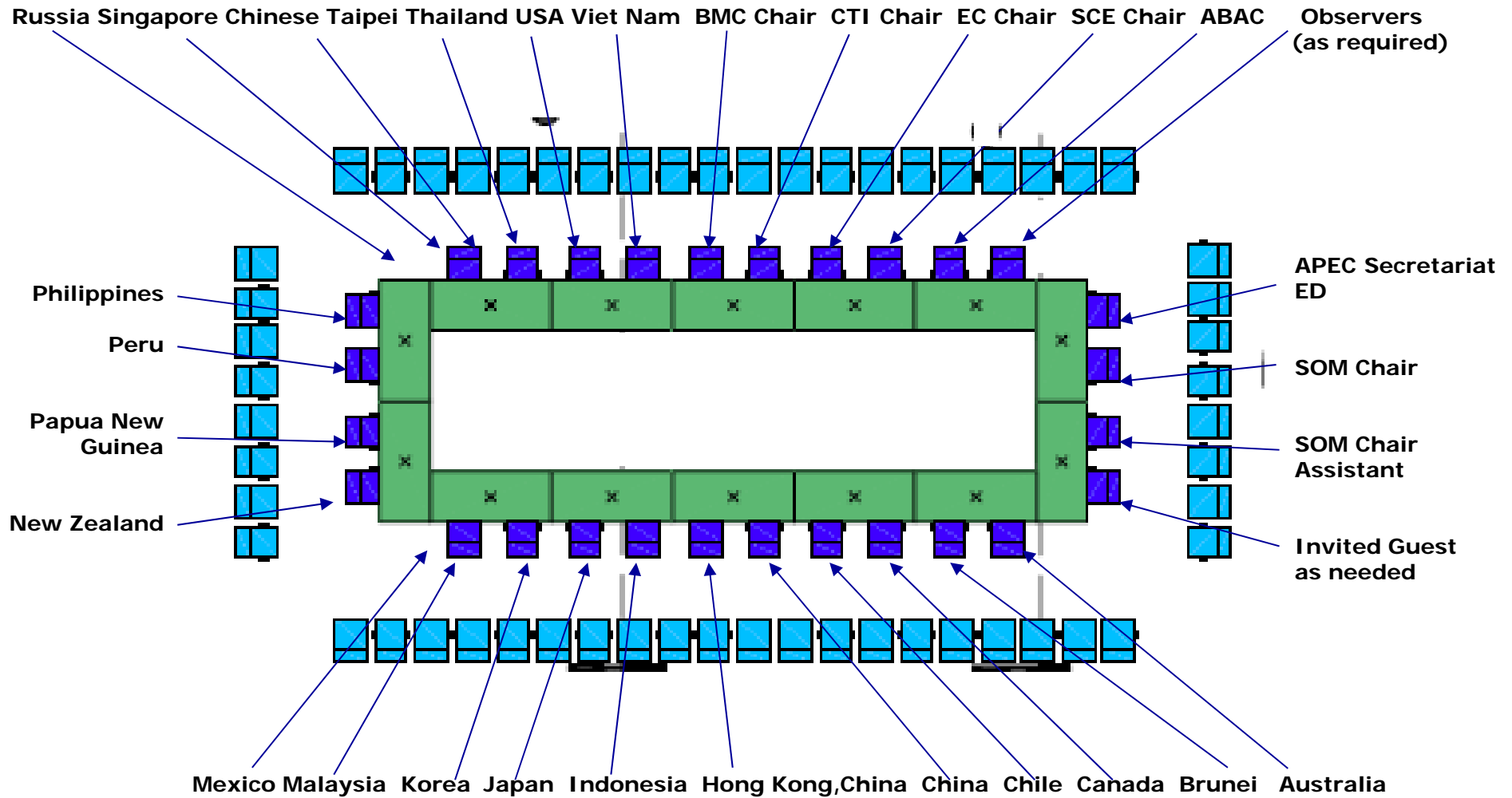

SOM Informal – Hollow Square Setup

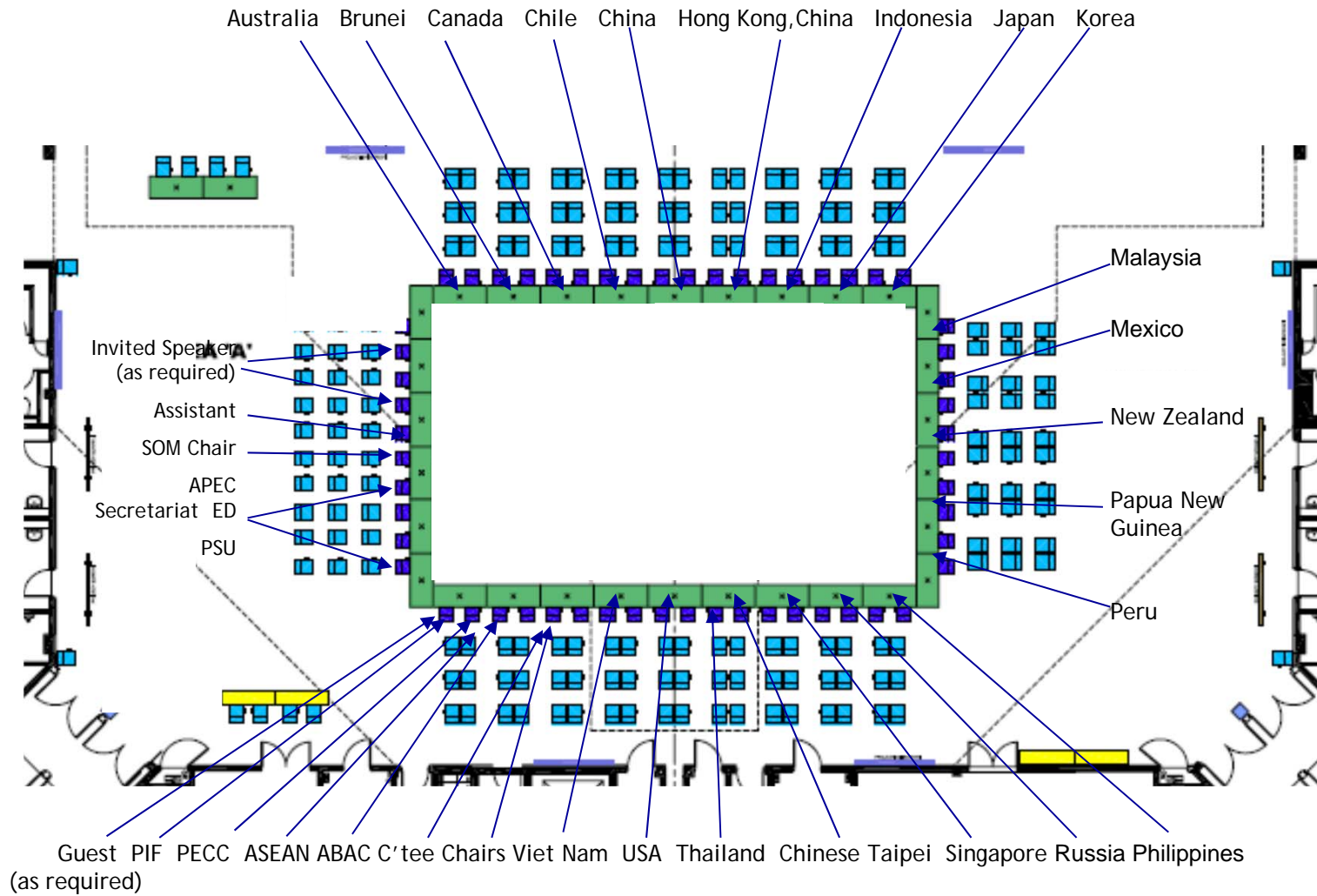

SOM Plenary Setup

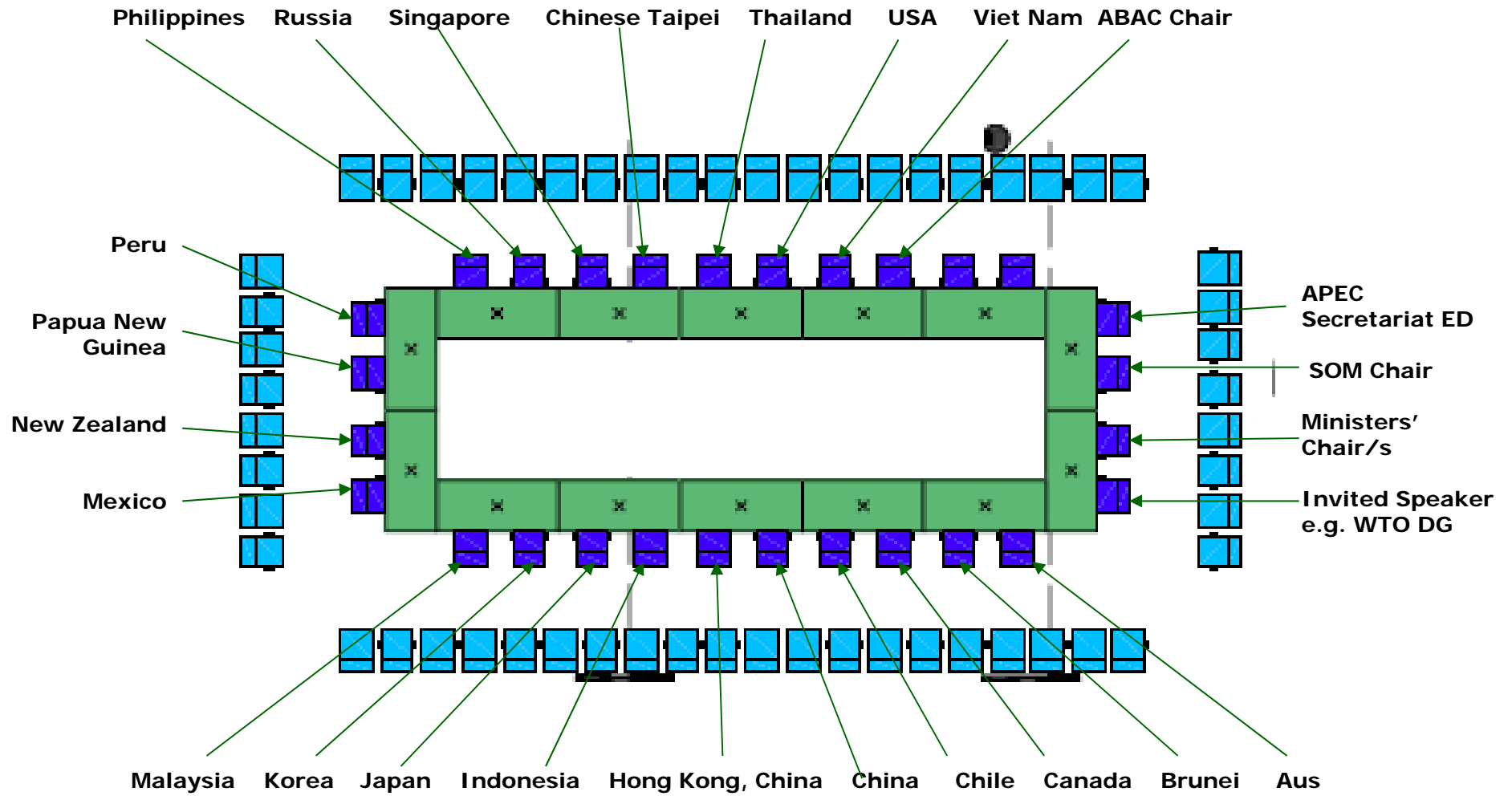

Ministers Retreat

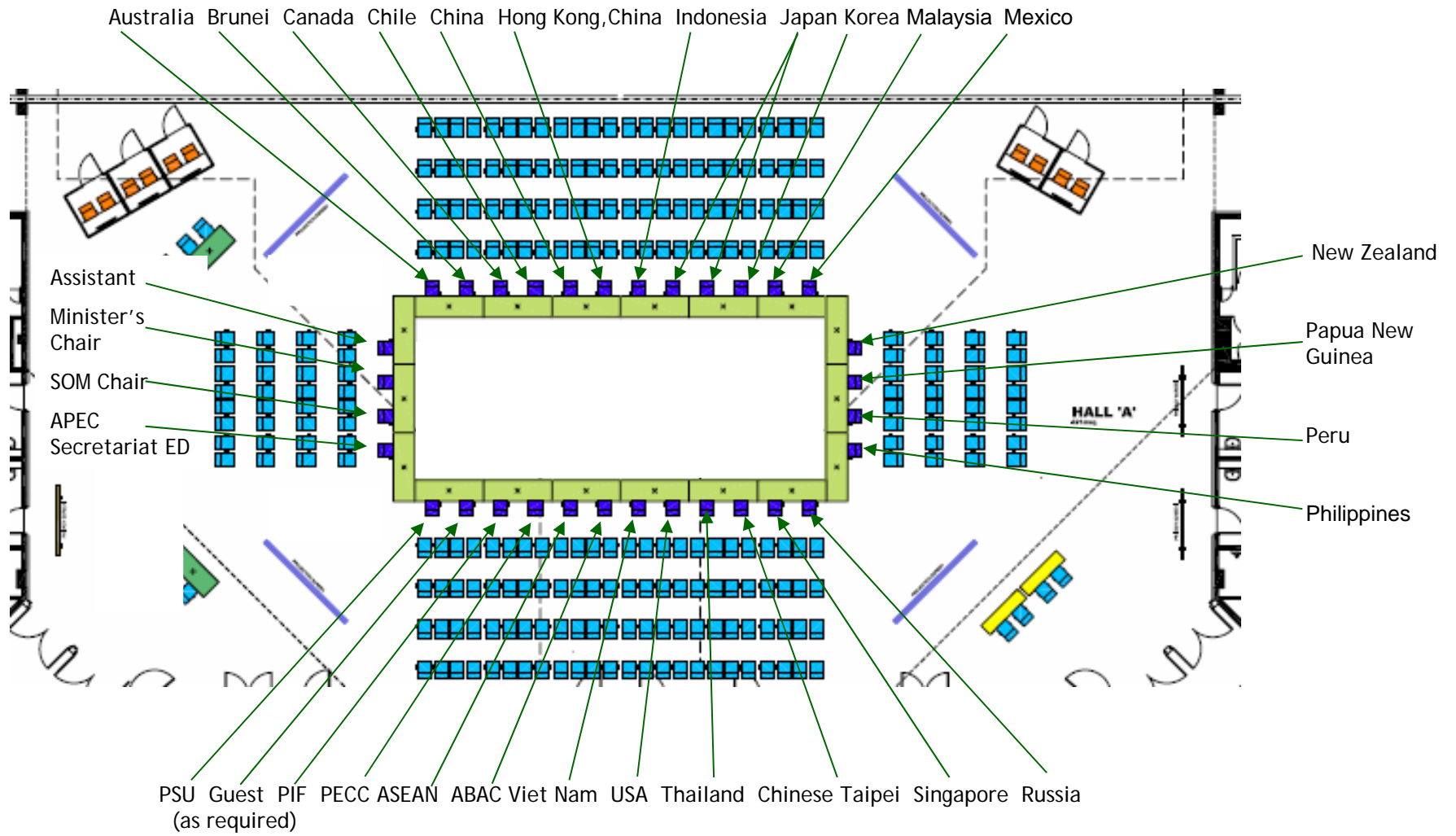

Ministerial Plenary